

# STAR 65

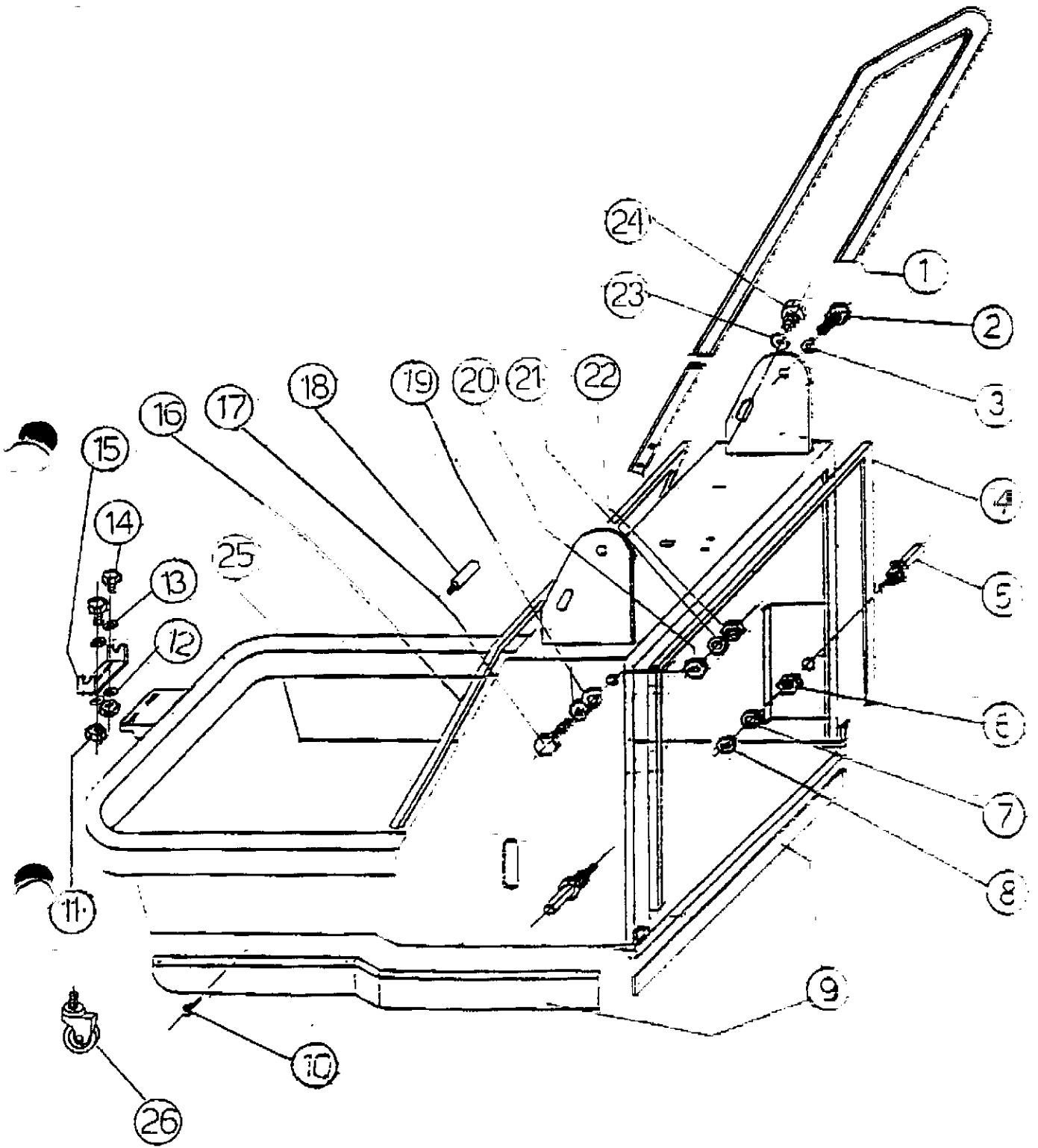

telaio tav. 1



N.FIG. DWG N.	N.CODICE PART N.	QUANT.	DENOMINAZIONE	DESCRIPTION
1	1.105.305	2	RONDELLA UNI 6592 10X21	10X21 WASHER
2	1.105.135	1	DADO AUTOBLOCK DIN 985 M10	AUTO-BLOCKING NUT
3	1.105.181	2	VITE TE FR 8X16	8X16 SCREW
4	2.370.001	1	ANTIVIB.APPOGGIO LATERALE	LAT.STAND ANTIVIBR.
5	1.270.003	1	TAMPONE REGOLAZ.SPAZZOLA	ADJUSTMENT'S PAD
6	1.110.007	1	GHIERA ZIGR.D.40 M8	KNURLED RING NUT
7	2.260.011	1	SUPPORTO BRACCIO LATERALE	LAT.LEVER ARM'STAND
8	1.320.008	1	VOLANTINO D.60 M10	HANDWHEEL
9	2.260.014	1	BRACCIO LATERALE	SIDE ARMS
10	2.130.008	1	DISTANZIALE MM 8	SPACER
11	1.390.008	1	CUSCINETTO 6201 2RS	BEARING
12	1.250.010	1	PULEGGIA DE:82	PULLEY
13	1.390.008	1	CUSCINETTO 6201 2RS	BEARING
14	2.290.003	1	PERNO BRACCIO LATERALE	SIDE ARM PIN
15	1.350.002	1	SPAZZOLA LATERALE PPL 50	PPL 50 SIDE BRUSH
	1.350.011	1	SPAZZOLA LATERALE PPL 70	PPL 70 SIED BRUSH
16	1.105.161	3	VITE TE FR 6X12	6X12 SCREW
	2.300.056		BRACCIO LAT.COMPL.Z60	Z.60 COMP.SIDE ARMS
	2.300.003		SUPPORTO BRAC.LAT COMPL.	COMPL.LAT.LEVER ARM'STAND

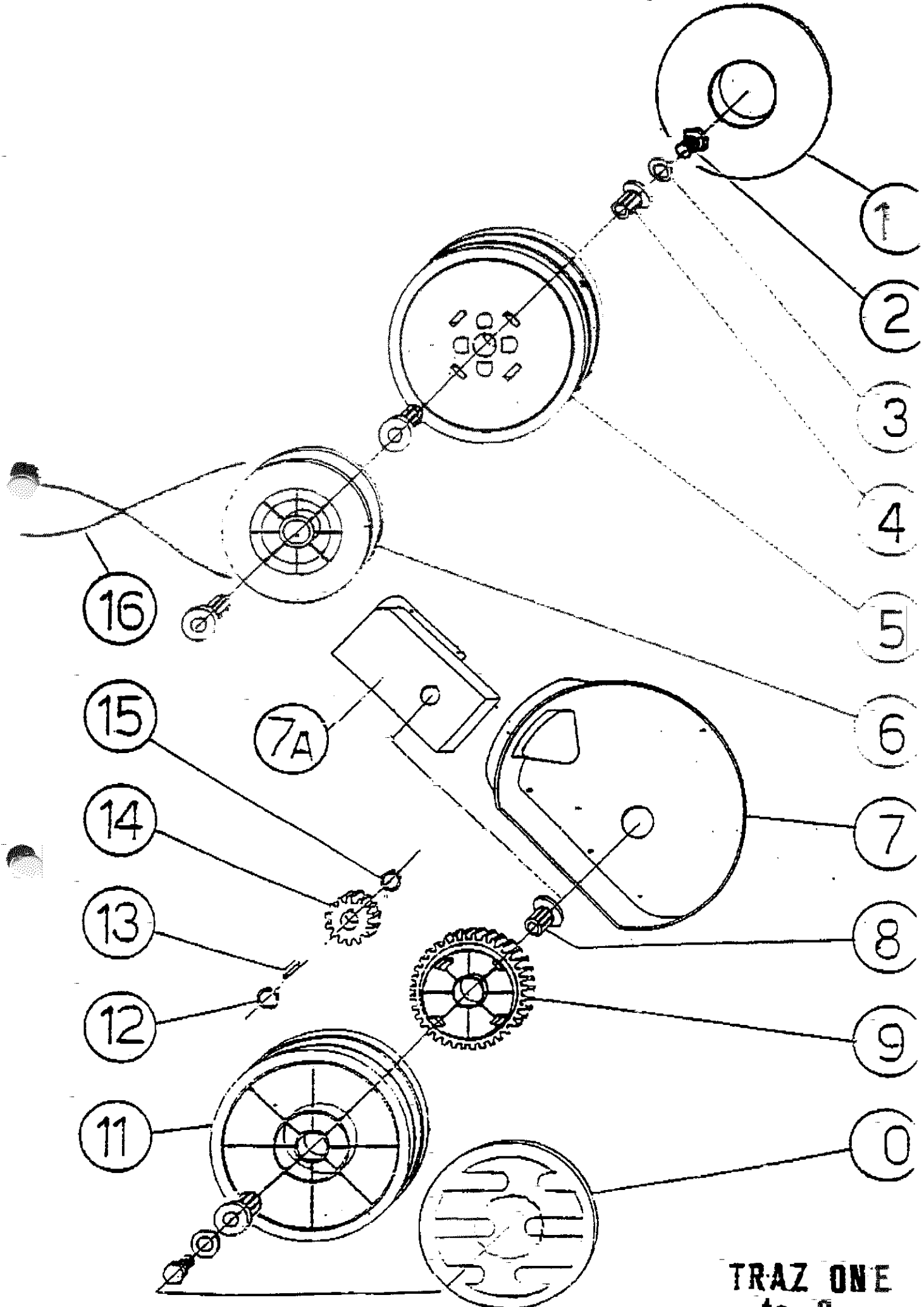

TRAZ ONE  
 tav 2



N.FIG. DWG N.	N.CODICE PART N.	QUANT.	DENOMINAZIONE	DESCRIPTION
1	2.120.013	1	COPRIR.D.250 SP25020 ROSSO	RED CORK
	2.120.071	1	COPRIR.D.250 SP25020 AZZ.	BLUE CORK
	2.120.070	1	COPRIR.D.250 SP25020 GIALLO	YELLOW CORK
	1.105.160	2	VITE TE FR 6X10	6X10 SCREW
	1.105.325	2	RONDELLA UNI 6593 6X24X3	6X24X3 WASHER
4	2.110.008	3	BOCCOLA D.20X15	BEARING
5	1.250.020	1	RUOTA 250 SP25020	+250 WHEEL
6	2.250.026	1	PULEGGIA DE 178 M.	PULLEY
7	2.120.014	1	CARTER LATERALE I	LATERAL CRANKCASE
7A	2.120.015	1	CARTER LAT.VECCHIO	OLD LATER.CRANKCASE
8	2.110.008	3	BOCCOLA D.20X15	BEARING
9	2.250.023	1	INGRANAGGIO DE 140 M	GEAR
10	2.120.013	1	COPRIRUOTA D.250 SP25020 R.	RED CORK
11	1.250.020	1	RUOTA D.250 SP25020	+250 WHEEL
12	1.105.405	1	SEEGER EST.DIN 471 D.15	SEEGER
13	1.105.461	1	CHIAVETTA UNI 6604 5X15	KEY
14	2.250.022	1	INGRANAGGIO DE 48	GEAR
15	1.105.405	1	SEEGER EST DIN 471 D.15	SEEGER
16	1.330.005	1	CINGHIA Z 60	BELT

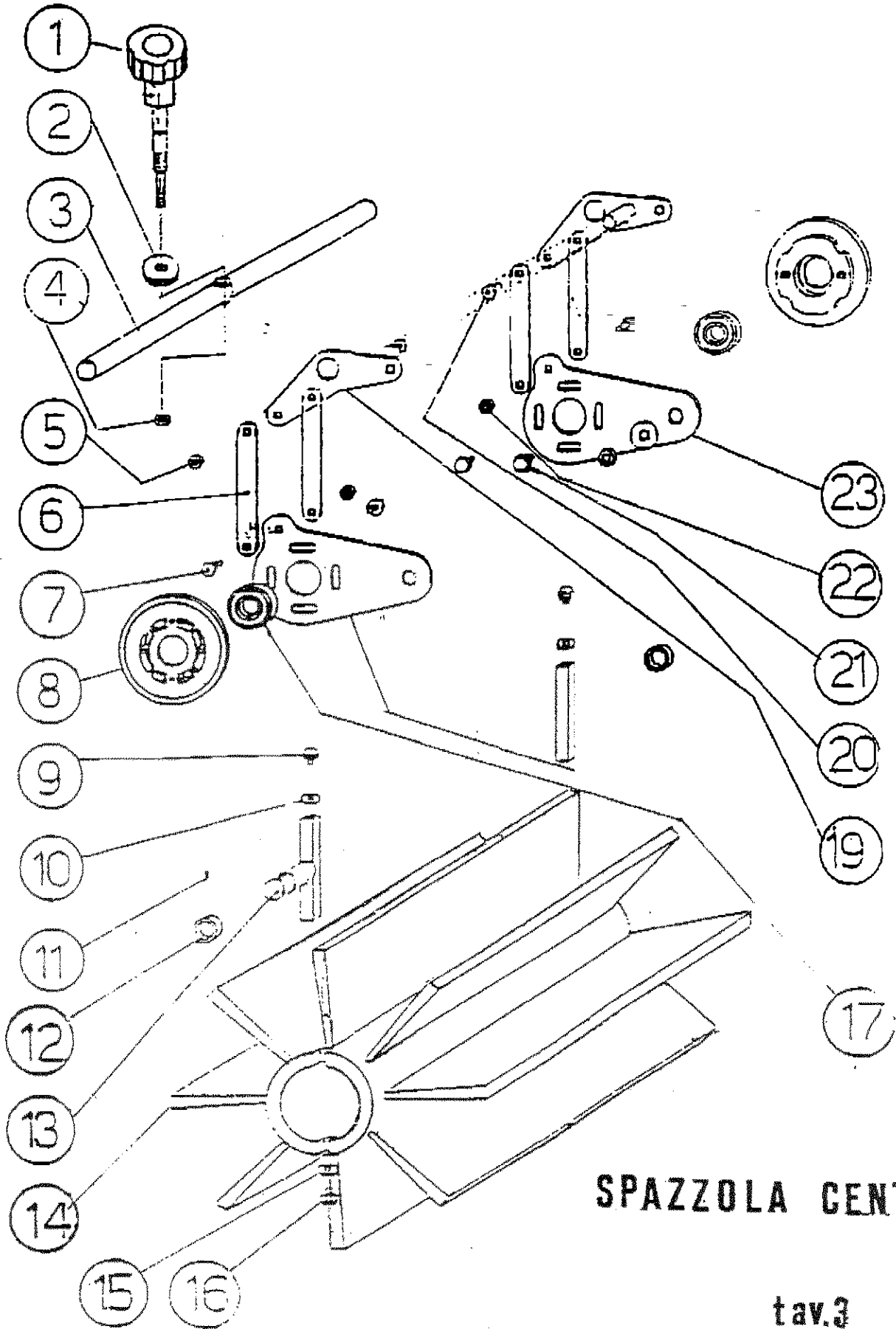

**SPAZZOLA CENTRAL**

tav.3



N.FIG. DWS N.	N.CODICE PART N.	QUANT.	DENOMINAZIONE	DESCRIPTION
1	1.320.031	1	VOLANTINO D.60 M12X67	M12X67 HANDWHEEL
2	1.105.304	2	RONDELLA UNI 6592 8X17	8X17 WASHER
	2.110.013	1	TUBO BILANCERE 65	65 ROCKER
4	1.105.134	1	DADO AUTOBLOK DIN 985 M8	M8 AUTO-BLOCKING NUT
5	1.105.133	2	DADO AUTOBLOK DIN 985 M6	M6 AUTO-BLOCKING NUT
6	2.190.003	4	STAFFA PER BILANCERE	ROCKER'S HANGER
7	1.105.042	2	VITE TE UNI 5739 6X16	6X16 SCREW
8	2.260.007	2	SUPPORTO CUSCINETTO BILANC.	BEARING STAND
9	1.105.160	2	VITE TE FR 6X10	6X10 SCREW
10	1.105.324	2	RONDELLA UNI 6593 6X18X2	6X18X2 WASHER
11	1.105.482	2	GRAND UNI 5923 6X6	6X6
12	2.130.003	2	DISTANZIALE ALB.SPAZ.TRAZ.	SPACER
13	2.100.001	1	ALBERO TRAZIONE SPAZZOLA	BRUSH TRACT.SHAFT
14	1.350.003	1	SPAZZ.CENTRALE 490 PPL30/40	30/40 CENTR.BRUSH
	1.350.006	1	SPAZZ.CENTRALE 490 PPL20/30	20/30 CENTR.BRUSH
	1.350.007	1	SPAZZ.CENTRALE 490 PPL40/50	40/50 CENTR.BRUSH
15	1.105.324	2	RONDELLA UNI 6593 6X18X2	6X18X2 WASHER
16	1.105.160	2	VITE TE FR 6X10	6X10 SCREW
17	1.390.009	2	CUSCINETTO 6202 2RS	BEARING
18	2.260.008	1	STAFFA SUPP.CUSCINETTO BIL.	BEARING'S STAND'S HANGER
19	2.110.014	1	BILANCERE 65	65 ROCKER
20	1.105.042	2	VITE UNI 5739 6X16	6X16 SCREW
21	1.105.160	4	VITE TE FR 6X10	6X10 SCREW
22	1.105.133	2	DADO AUTOBLOK DIN 985 M6	M6 AUTO-BLOCKING NUT
23	2.260.008	1	STAFFA SUPP.CUSCINETTO BIL.	BEARING'S STAND'S HANGER
24	2.100.011	1	ALBERO SPAZZOLA	BRUSH SHAFT
	2.300.012		BILANCERE COMPLETO 65	65 COMPL.ROCKER

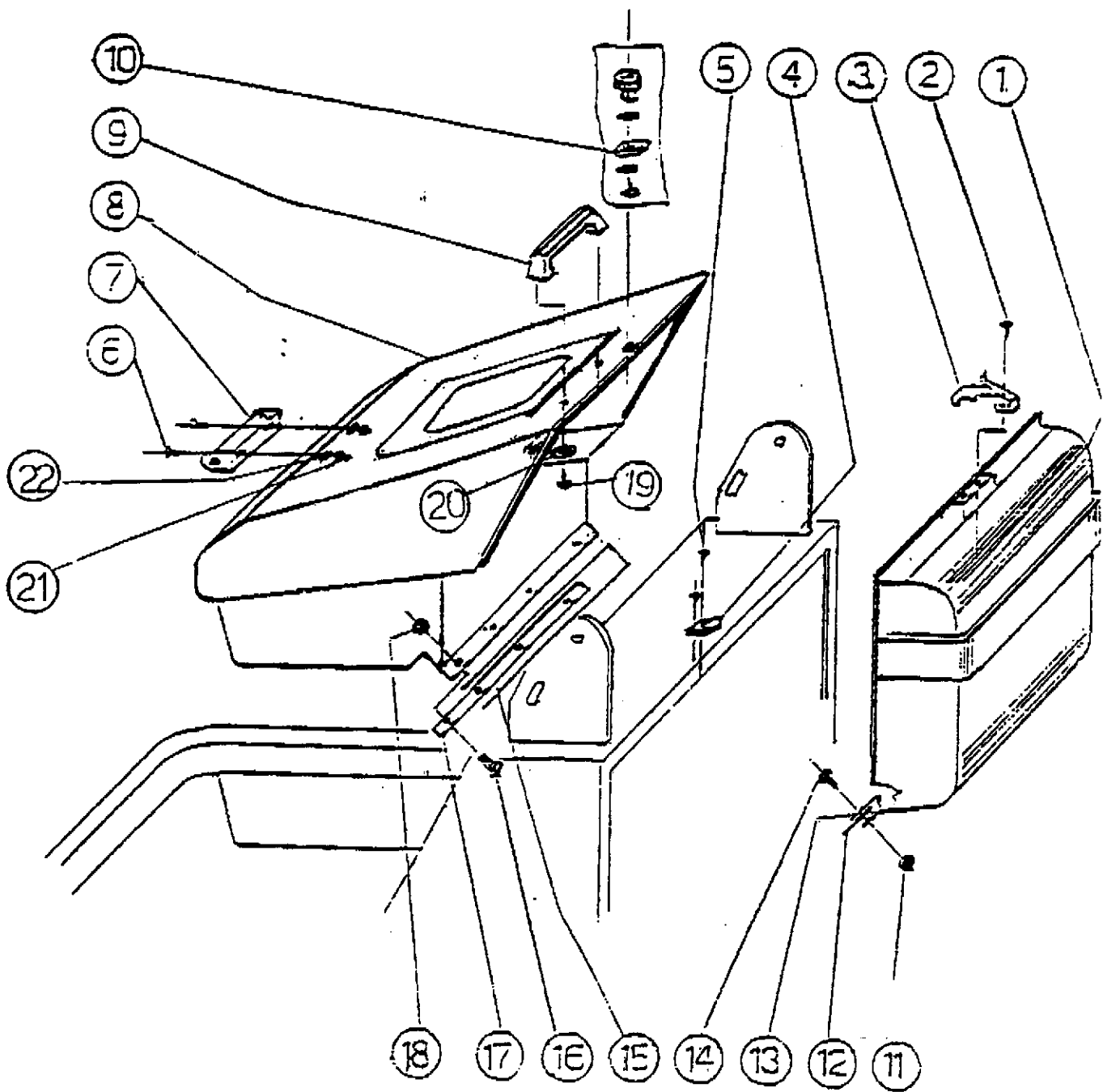

cofani tav 4

N.FIG. DWG N.	N.CODICE PART N.	QUANT.	DENOMINAZIONE	DESCRIPTION
1	2.120.027	1	CASSETTO POSTERIORE ROSSO	RED REAR DRAWER
	2.120.057	1	CASSETTO POSTERIORE AZZ.	BLUE REAR DRAWER
	2.120.076	1	CASSETTO POSTERIORE BIANCO	WHITE REAR DRAWER
	2.120.049	1	CASSETTO POST.LAM.GIALLO	YELLOW PAIN.REAR DRAWER
	2.120.045	1	CASSETTO POST.LAM.ROSSO	RED PAIN.REAR DRAWER
2	1.105.354	2	VITE AUT.TCUNI 6954 3,5X13	3,5X13 SCREW
3	1.320.002	1	CHIUSURA A LEVA	CLOSING STOP
4	1.320.007	1	RISCONTRO CHIUSURA A LEVA	LEVER ACTION CLOSING STOP
5	1.105.356	2	VITE AUT.TCUNI 6594 3,5X9,5	3,5X9,5 SCREW
6	1.105.162	2	VITE TE FR 6X16	6X16 SCREW
7	2.260.001	1	SUPPORTO CASS.ANTERIORE	FORE DRAWER'S STAND
8	2.120.011	1	CASSETTO ANTERIORE ROSSO	RED FORE DRAWER
	2.120.052	1	CASSETTO ANTERIORE AZZ.	BLUE FORE DRAWER
	2.120.075	1	CASSETTO ANTERIORE BIANCO	WHITE FORE DRAWER
	2.120.047	1	CASSETTO ANT.LAM.GIALLO	YELLOW PAIN.FORE DRAWER
	2.120.043	1	CASSETTO ANT.LAM.ROSSO	RED PAIN.FORE DRAWER
9	1.320.006	1	MANIGLIA 135 MB	HANDLE
10	1.320.001	1	SERRAT.CASS.ANTERIORE	FORE DRAWER'S LOCK
11	1.105.121	4	DADO UNI 5588 M4	M4 NUT
12	2.160.018	1	GOMMA CASS.POSTERIORE 65	65 REAR FLAP
13	2.150.012	1	FERMO GOMMA CASS.POST.	REAR TYRE STOP
14	1.105.001	4	VITE TE UNI 5739 4X12	4X12 SCREW
15	2.160.015	1	GOMMA CASS.ANTERIORE 65	65 FORE FLAP
	1.105.001	4	VITE TE UNI 5739 4X12	4X12 SCREW
17	2.150.009	1	FERMO GOMMA CASS.ANT.	FORE TYRE STOP
18	1.105.121	4	DADO UNI 5588 M4	M4 NUT
19	1.105.181	2	VITE TE FR 8X16	8X16 SCREW
20	1.105.325	2	RONDELLA UNI 6593 6X24X2	6X24X2 WASHER
21	1.105.123	2	DADO UNI 5588 M6	M6 NUT
22	1.105.325	2	RONDELLA UNI 6593 6X24X2	6X24X2 WASHER
	2.300.034/R		CASS.POST.COMPL.ROSSO	COMP.RED REAR DRAWER
	2.300.035/A		CASS.POST.COMPL.AZZ.	COMP.BLUE REAR DRAWER
	2.300.036/B		CASS.POST.COMPL.BIANCO	COMP.WHITE REAR DRAWER
	2.300.027/RL		CASS.POST.COMPL.LAM.ROSSO	COMP.RED PAIN.REAR DRAWER
	2.300.028/GL		CASS.POST.COMPL.LAM.GIALLO	COM.YELLOW PAIN.REAR DRAWER
	2.300.031/R		CASS.ANT.COMPL.ROSSO	COMP.RED FORE DRAWER
	2.300.032/A		CASS.ANT.COMPL.AZZ.	COMP.BLUE FORE DRAWER
	2.300.033/B		CASS.ANT.COMPL.BIANCO	COMP.WHITE FORE DRAWER
	2.300.023/RL		CASS.ANT.COMPL.LAM.ROSSO	COMP.RED PAIN.FORE DRAWER
	2.300.024/GL		CASS.ANT.COMPL.LAM.GIALLO	COM.YELLOW PAIN.FORE DRAWER



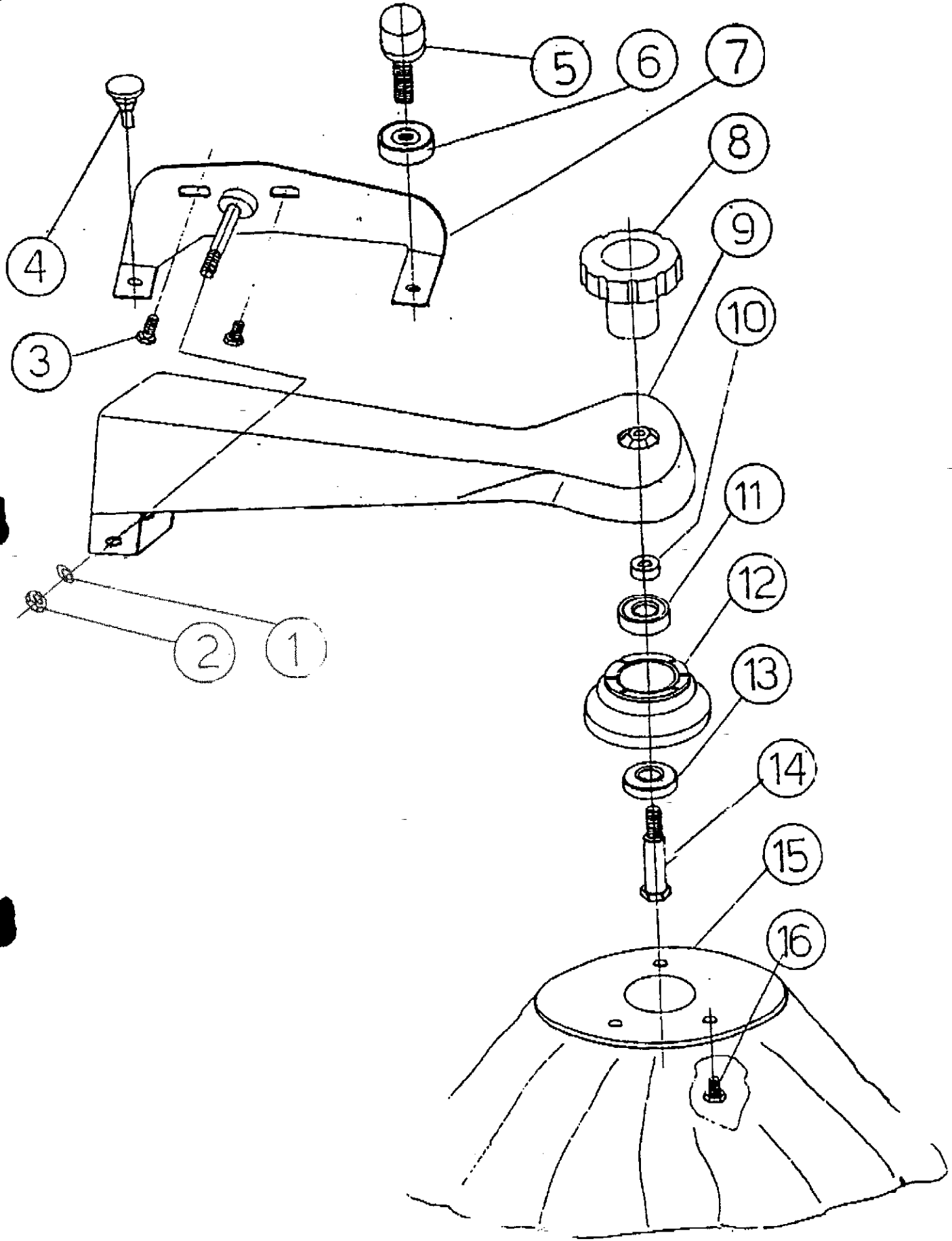

**SPAZZOLA-LATERAL**

**TAV 5**



STAR 65

TELAIO

TAV 1

N.FIG. DWG N.	N.CODICE PART N.	QUANT.	DENOMINAZIONE	DESCRIPTION
1	2.200.013	1	MANICO NERO	BLACK HANDLE
	2.200.017	1	MANICO BIANCO	WHITE HANDLE
	2.200.019	1	MANICO ROSSO	RED HANDLE
	1.105.181	2	VITE TE FR 8X16	8X16 SCREW
3	1.105.304	4	RONDELLA UNI 6592 8X17	8X17 WASHER
4	2.160.009/1	1	MOUSSE AD.15X5 C.POS.L.110	L.110 ADHESIVE MOUSSE
5	2.230.008	2	PERNO RUOTA MANUALI	WHEEL'S PIN
6	1.105.221	2	DADO UNI 5589 M18	M18 SCREW NUT
7	1.105.325	2	RONDELLA UNI 6593 6X24X2	6X24X2 WASHER
8	1.105.134	2	DADO AUTOBLOCK DIN 985 M8	M8 AUTO-BLOCKING NUT
9	2.310.004	1	KIT GOMME FLAP TELAI0	FLAP TYRES SET
10	1.105.356	12	VITE AUT.TCUNI 6954 3,5X9,5	3,5X9,5 SCREW
11	1.105.123	2	DADO UNI 5588 M6	M6 NUT
12	1.105.324	2	RONDELLA UNI 6593 6X18X2	6X18X2 WASHER
13	1.105.325	2	RONDELLA UNI 6593 6X24X2	6X24X2 WASHER
14	1.105.162	2	VITE TE FR 6X16	6X16 SCREW
15	2.110.001	1	BASE SUP.CAS.ANTERIORE	FORE DRAWER'S STAND
16	1.160.002	1	MOUSSE ADES.10X8 C.ANT.L100	L100 ADHESIVE MOUSSE
17	1.105.066	2	VITE TE UNI 5739 8X35	8X35 SCREW
18	2.230.005	1	PERNO SOSTEGNO CINGHIA	BELT'S BRACE PIN
19	1.105.326	4	RONDELLA UNI 6593 8X24X2,5	8X24X2,5 WASHER
20	1.105.124	2	DADO UNI 5588 M8	M8 NUT
	1.105.304	2	RONDELLA UNI 6592 8X17	8X17 WASHER
	1.105.134	2	DADO AUTOBLOCK DIN 985 M8	M8 AUTO-BLOCKING NUT
23	1.105.304	2	RONDELLA UNI 6592 8X17	8X17 WASHER
24	1.320.030	2	VOLANTINO D.40 M8X15	D.40 HANDWHEEL
25	2.270.043	1	TELAIO NERO	BLACK FRAME
	2.270.057	1	TELAIO BIANCO	WHITE FRAME
	2.270.065	1	TELAIO ROSSO	RED FRAME
26	2.250.039	1	RUOTA D.80 SUPP.BIR.L.40	L.40 TURNING + 80 WHEEL