



# "Little Wonder"



DIVISION OF SCHILLER-PFEIFFER, INCORPORATED

1028 STREET ROAD

SOUTHAMPTON, PA. 18966 U.S.A.

AREA CODE 215-357-5110

## OPERATING, ASSEMBLY INSTRUCTIONS, AND PARTS LIST FOR THE LITTLE WONDER BLOWERS — CAT. Nos. 9005S, 9005P, 9005PIC, 9008S, 9008P, 9008PIC, 9008K, 9011P, 9011PIC

### IMPORTANT SAFETY INSTRUCTIONS

1. READ AND FOLLOW ALL INSTRUCTIONS.
2. DRESS PROPERLY — Do not wear loose clothing or jewelry. They can be caught in moving parts. Use of sturdy gloves, non-skid footwear and safety glasses recommended. Always wear ear protectors where possible. Use face filter to avoid breathing dust.
3. STAY ALERT — Watch what you are doing and use common sense. Do not operate blower when fatigued.
4. DANGER — KEEP HANDS AWAY FROM AIR INTAKE AND AIR OUTLET CHUTE — Keep both hands on handles when power is on. Do not attempt to remove material when blower is running.
5. **WARNING** — DO NOT INSTALL OR REMOVE ATTACHMENTS WHILE BLOWER IS RUNNING. Turn off engine to make changeover.
6. KEEP CHILDREN AND INCAPABLE PERSONS AWAY — Do not permit children to contact blower. Keep children a safe distance from work area. Never allow a person mentally ill, under influence of alcoholic drinks or drugs, or too young in age, to operate the blower. Do not point the blower outlet in the direction of people, cars, glass or other similar items which could be damaged. Do not allow bystanders, or animals in work area.
7. DON'T OVERREACH OR STAND ON UNSTABLE SUPPORT — Keep good footing and balance at all times.
8. HANDLE GASOLINE WITH CARE. IT IS HIGHLY INFLAMMABLE. Refuel before starting work. Do not smoke while handling fuel. Do not refuel a hot engine. Avoid spilling fuel or oil. Always wipe unit dry before using. Move at least 10 feet away from the fueling point before starting engine. Always store gasoline in an approved container.
9. CAUTION — Do not start or run engine indoors as poisonous carbonmonoxides are emitted. Do not operate in unventilated area.
10. MULTIPLE OPERATORS — Keep a safe distance between two or more operators when working together simultaneously.
11. DO NOT USE the blower when electric system causes spark outside the cylinder. Check spark plug from time to time. When checking, keep plug a safe distance from cylinder to avoid burning of evaporated fuel from cylinder.
12. MAINTAIN AND EXAMINE BLOWER WITH CARE — Follow maintenance instructions given in manual. Do not use the blower if the muffler is defective or missing.
13. STORE BLOWER INDOORS — When not in use, store blower indoors in a sheltered area (a dry place) where not accessible to children. The blower, as well as fuel, should not be stored in a house.
14. DO NOT ATTEMPT TO REPAIR BLOWER — Have repairs made by qualified dealer or repairman. See that only identical replacement parts are used.
15. BE SURE BLOWER IS FULLY ASSEMBLED — Never operate blower without all guards and deflectors in place. Ensure that all nuts, bolts, screws are installed and properly tightened.

16. ALWAYS KEEP THE THROTTLE IN THE "STOP" POSITION WHEN NOT IN USE.
17. IN ORDER TO AVOID ENGINE DAMAGE DUE TO OVER REVOLUTION, DO NOT BLOCK INTAKE OR AIR OUTLET CHUTE OR HOSE ACCESSORIES.

### ASSEMBLY INSTRUCTIONS:

**\*NOTE:** Numbers in brackets (-) represent Assembly Item Numbers shown on Parts List.

- A. Install lower handle (1) and handle support (1a) under deck in the notches provided. Secure with two cap screws (2) and two nuts (3) (finger tight). See illustration.

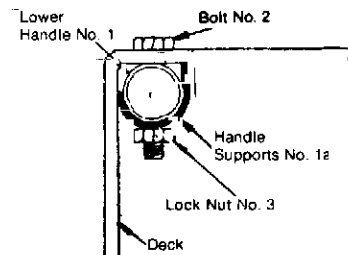

- B. Install handle brace (5) to engine stud with nut (4) & washer (19) (finger tight).

#### C. (Catalog No. 9005S)

Connect handle brace (5) to lower handle (1) with cap screw (2) and nut (3). Install upper handle (6) with four bolts (7) and four nuts (8). Throttle bolt hole should be on **right** side of unit when standing behind blower. Secure all nuts and bolts with wrench. Do not tighten bolts until all handles are in place.

(Catalog Nos. 9005P, 9005P.I.C., 9008S, 9008P, 9008P.I.C., 9011P, and 9011P.I.C.)

Install upper handle (6) with four bolts (7) and four nuts (8). Throttle bolt hole should be on **right** side of unit when standing behind blower. Connect handle brace (5) to upper handle (6) with cap screws (2) and nuts (3). Secure all nuts and bolts with wrench. Do not tighten bolts until all handles are in place.

#### (Catalog No. 9008K)

Install upper handle (6) with four bolts (7) and four nuts (8). Throttle bolt hole should be on **left** side of unit when standing behind blower. Connect handle brace (5) to upper handle (6) with cap screws (2) and nuts (3). Secure all nuts and bolts with wrench. Do not tighten bolts until all handles are in place.

- D. Attach throttle with bolt (9) and nut (8) thru hole provided in upper handle (6), and connect throttle cable clip (10) to upper handle (6).
- E. Tilt machine back on handle and install front wheel housing (11) to three studs on lower front of blower housing. Secure with three nuts (4).
- F. Insert axle sleeve (12) in wheel (13) and install on front wheel housing (11) with axle bolt (14), secure with axle nut (15).
- G. Install clamp (16) and wing nut (17) to stud at top front of blower housing.
- H. Insert intake guard assembly (18) and tighten wing nut (17) and clamp (16).

## OPERATING INSTRUCTIONS

Be sure to read the applicable Briggs & Stratton or Kohler instruction manuals packed with the respective units. "Do not forget to put oil in the engine."

Your Little Wonder Blower eliminates the drudgery usually associated with a manually operated tool such as a rake or broom, and is very easy to use.

Leaves, thatch or other debris can be directed into windows or piles simply by maneuvering the unit and directing the flow of air accordingly.

Air flow can be directed to the side or front by two-position deflector. The front discharge position is used to remove debris from along walls, fences, etc. Side discharge position is used to form windrows or piles. The horizontal deflector directs air downward to "chisel" under wet, heavy leaves and litter. The velocity of air is regulated by the throttle control.

## USER MAINTENANCE INSTRUCTIONS

1. Keep all nuts, bolts and screws tight.
2. Never store the Blower with fuel in the fuel tank inside a building where fumes may reach an open flame or sparks, or in a confined space such as a car trunk.
3. Always refer to the instruction manual for important details if the product is to be stored for an extended period.
4. CAUTION — After approximately the first three (3) to four (4) hours of operation, tighten the bolt holding the fan to a torque of 40 foot pounds or 480 inch pounds! "LOCTITE" 242 has been used on the engine shaft to secure the fan on the shaft.
5. Engine — 4 cycle. (Refer to engine manufacturer's operating instructions for fuel recommendation and additional information).
6. Tires — Tubeless. Inflate to air pressure of 30 P.S.I.

## PROCEDURE FOR FAN REMOVAL

1. Remove all bolts and nuts securing the engine to deck, blower housing, and handles.
2. Remove intake guard and front panel.
3. Remove bolt securing fan to engine crankshaft.
4. The fan has a 3/4-10 nut welded on the fan hub. Insert a 3/4-10 bolt and jack or push the engine off the fan. In some instances, it may be necessary to apply heat in area of fan hub as Loctite 242 has been used to secure the fan on the engine crankshaft. Be careful not to overheat.
5. Reassemble with Loctite 242 to insure a snug fit.

## PARTS:

All replacement parts may be ordered through your local dealer, distributor or from our plant in Southampton, Pa. Orders from our plant will be shipped via parcel post, UPS, or motor freight F.O.B. Southampton, Pa.

## FEATURES:

- 35% greater air power.
- Smooth rolling big front wheel for easy operation on uneven ground.
- Downward deflector to lift heavy litter and wet leaves.
- Heavy gauge 3/16" steel plate deck. Blower housing is 12 gauge steel arc welded.
- Handy lifting handle on intake guard for easy lifting in and out of trucks, station wagons, etc.
- Starter handle in the clear for right or left hand starting.
- Low-tone mufflers for noise dampening.
- Dual element air cleaner.

## MANY USES:

The extreme versatility offered by Little Wonder's line of blowers makes them ideally suited for a wide variety of jobs — blowing leaves, grass clippings, and thatch, blowing tennis courts dry, cleaning large driveways, stadiums, parking lots and other hard surfaces, and precleaning roofs before repair.

## LIMITED SERVICE & WARRANTY POLICY

All "Little Wonder" products are guaranteed against defects in material and workmanship for a period of ONE YEAR FROM DATE OF PURCHASE when used for RESIDENTIAL SERVICE, NINETY DAYS FROM DATE OF PURCHASE for COMMERCIAL SERVICE. Any "Little Wonder" products or parts found to be defective within the warranty period are to be returned to our factory at Southampton, PA.

Transportation charges on parts and units submitted for replacement under this warranty must be borne by purchaser.

Engines for gas powered products are warranted separately by the engine manufacturer. Therefore, there are no warranties made, expressed or implied, for engines for gas powered products by "Little Wonder".

THIS WARRANTY shall not be effective if the product has been the subject of misuse, negligence or accident, or, if the product has been repaired or altered outside of our Southampton factory in any respect which affects its condition or operation.

**"Little Wonder" shall not be liable for any special indirect or consequential damages arising from defective equipment. Any implied warranty, including merchantability or fitness for a particular purpose, shall not extend beyond the written warranty period.**

THIS WARRANTY shall be effective only providing enclosed card is properly filled out and returned to "Little Wonder, Div. of Schiller-Pfeiffer, Inc." at time of purchase.

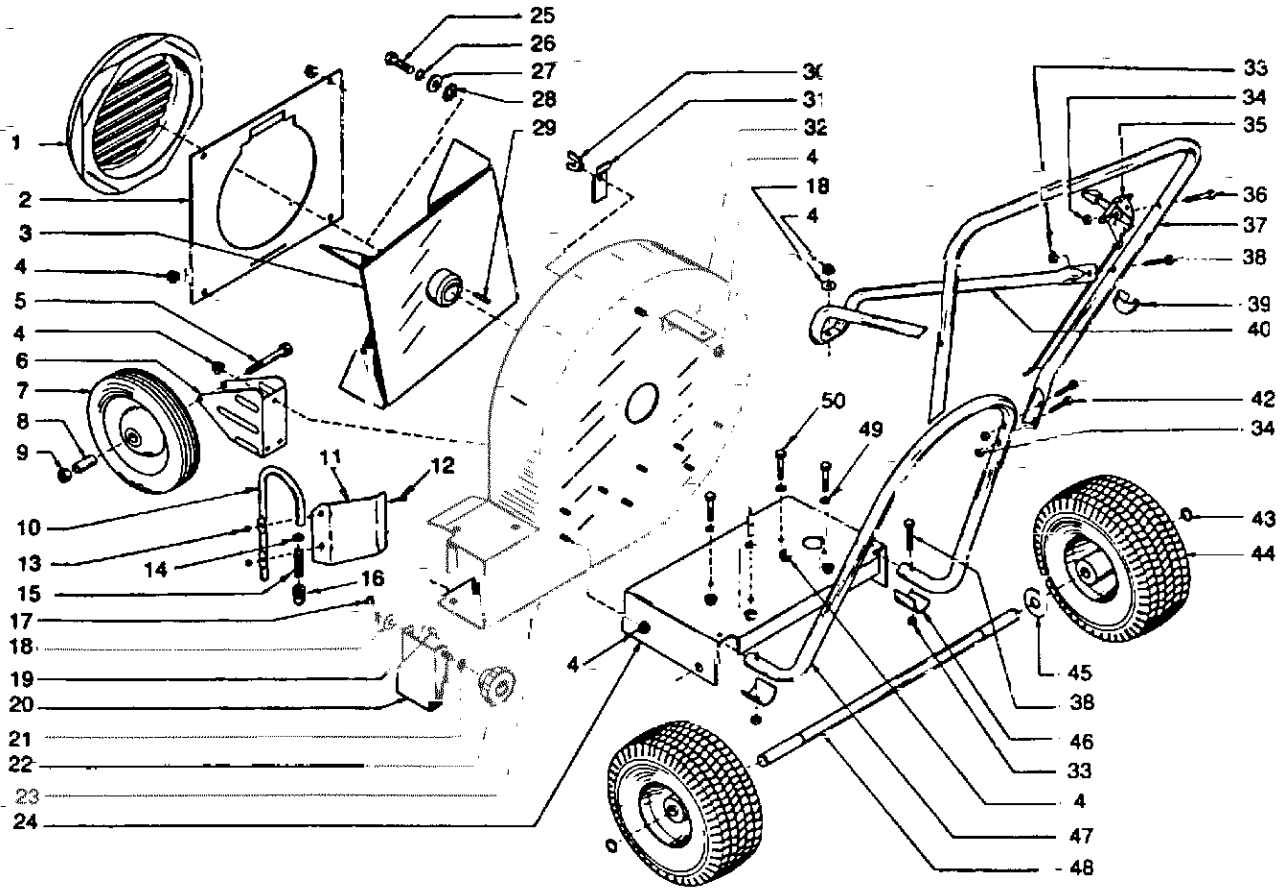

CATALOG #9005S

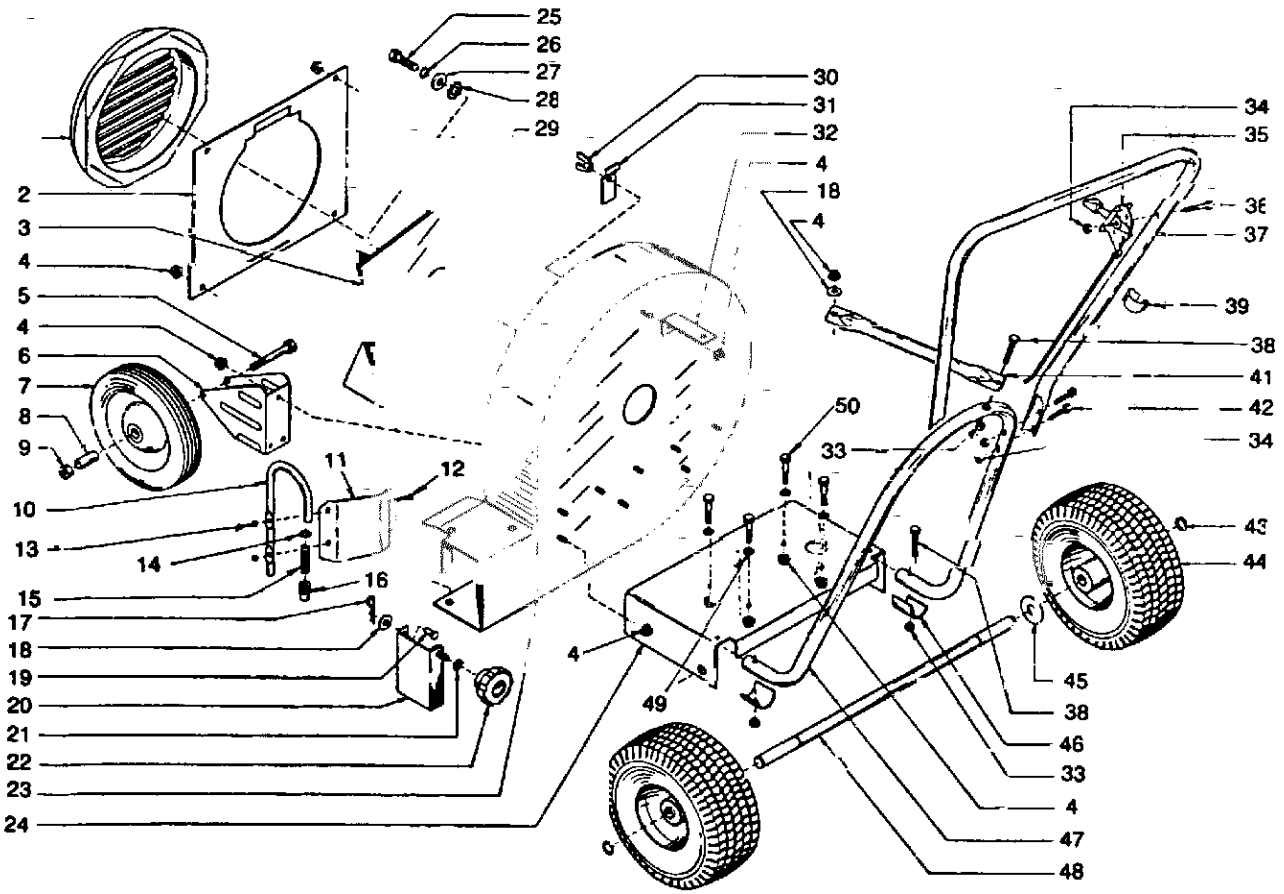

# CATALOG #9008K

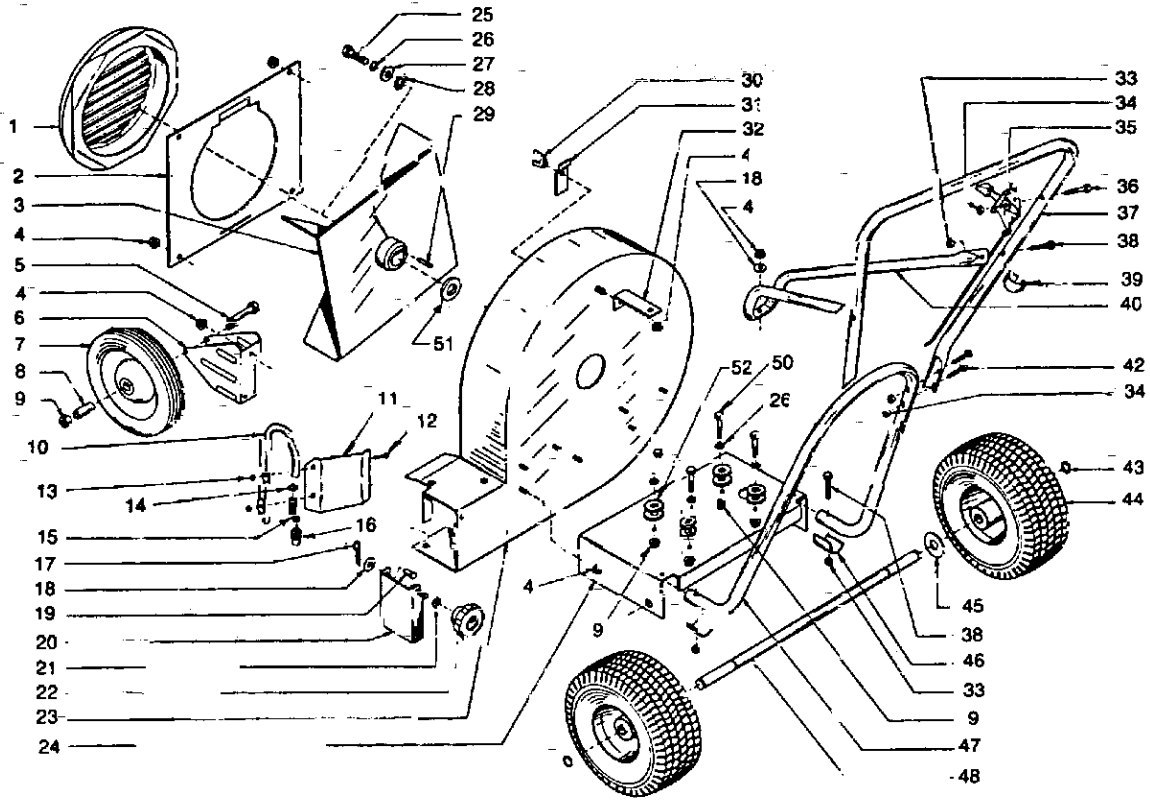

**ATTACHMENTS:** Due to the adaptability and versatility of the Little Wonder Blower, several options and accessories are available as illustrated below.

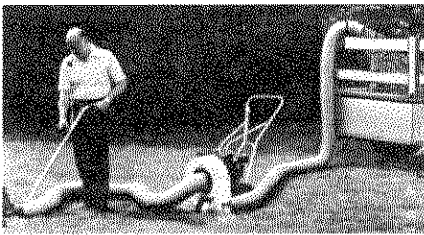

6" diameter x 10 foot long intake hose (Cat. #9015) with 6" diameter x 20 foot long truck loader hose (Cat. #9022).



(Cat. #9016) 6" Diameter x 10 foot long intake hose with bagging attachment.

## ATTACHMENTS — ACCESSORIES

CAT. #	DESCRIPTION
	Standard intake hose (6" I.D. x 10'-0" L.G.) with handle and mounting flange.
9016	Standard intake hose with bagging attachment.
9018	Heavy duty intake hose with wear strip (6" I.D. x 10'-0" L.G.) with handle and mounting flange.
9019	Bagging attachment (no hose included).
9022	Loading hose (6" I.D. x 20'-0" L.G.).
	Side deflector kit for 5 H.P. blowers. Cat. #9005S, 9005P, 9005P.I.C.
	Side deflector kit for 8 H.P. blowers. Cat. #9008P, 9008S, 9008K, 9008P.I.C. and 11 H.P. blowers Cat. #9011, and 9011P.I.C.
	Bag.

## STORAGE AFTER USE

- Inspect and adjust every part of the unit.
  - Completely clean every part and repair, if necessary.
  - Apply thin coating of clean oil on metal parts to prevent rust.
- Remove hose accessories from blower (if applicable).
- Place throttle control in the "stop" position.
- Drain fuel tank, pull the starter handle slowly a few times to drain fuel from carburetor.
- Pour a small amount of clean motor oil into spark plug hole of cylinder, pull starter handle and then manually crank the engine until TOP DEAD CENTER.
- Store in a dry area, free from dust.

# PARTS LIST

ASSY. ITEM NO.	KEY NUMBER	PART NUMBER	DESCRIPTION	QUANTITY PER UNIT							CATALOG NUMBERS	
				9005S	9005P	9005PIC	9008S	9008P	9008PIC	9008K	9011P	9011PIC
(18)	1	954-1	Intake Guard Assy.	1	1		1	1	1	1	1	
	2	929-1	Cover Plate	1	1		1	1	1	1	1	
	3	907	Fan Assembly 5 H.P.	1	1							
	3	913	Fan Assembly 8 H.P.				1	1	1	1	1	1
(4)	4	114B	Flange Lock Nut 5/16-18	21	21	21	21	21	21	17	21	21
(14)	5	102A	Axle Bolt 3/8-16 x 3" lg.	1	1	1	1	1	1	1	1	1
(11)	6	944	Wheel Housing	1	1	1	1	1	1	1	1	1
(13)	7	106	8" Symmetrical Wheel	1	1	1	1	1	1	1	1	1
(12)	8	102C	Axle Sleeve	1	1	1	1	1	1	1	1	1
(15)	9	102B	Lock Nut 3/8-16	1	1	1	1	1	1	5	1	1
	10	970	Deflector Handle	1	1	1	1	1	1	1	1	1
	11	966	Deflector	1	1	1	1	1	1	1	1	1
	12	329	Bolt 10-32 x 5/8	2	2	2	2	2	2	2	2	2
	13	973	Lock Nut 10-32	2	2	2	2	2	2	2	2	2
	14	8-18	Grip Ring	1	1	1	1	1	1	1	1	1
	15	952	Spring	1	1	1	1	1	1	1	1	1
	16	967	Index Slide Lock Bushing	1	1	1	1	1	1	1	1	1
	17	418-1	Hitch Pin Clip #13	1	1	1	1	1	1	1	1	1
(19)	18	163	Washer — Fiat 3/8	2	2	2	2	2	2	2	2	2
	19	170	Clevis Pin	1	1	1	1	1	1	1	1	1
	20	936	Side Deflector 5 H.P.	1	1	1						
	20	937	Side Deflector 8 H.P.				1	1	1	1	1	1
	21	963	External Tooth Lock Washer	1	1	1	1	1	1	1	1	1
	22	154	Knob	1	1	1	1	1	1	1	1	1
	23	902	Blower Housing 5 H.P.	1	1	1						
	23	905	Blower Housing 8 H.P.				1	1	1	1	1	1
	24	900	Deck 5 H.P.	1	1	1						
	24	901	Deck 8 H.P.									
	24	901-11	Deck 11 H.P.									
	24	901K	Deck 8 H.P. Kohler							1	1	1
	25	939	Bolt Grade 5; 3/8-24 N.F. x 1 1/4" lg.	1	1	1						
	25	938	Bolt Grade 5; 7/16-20 N.F. x 1 1/2" lg.	1	1	1	1	1	1	1	1	1
	26	941	Lockwasher — Split 3/8	1	1	1				4	4	4
	26	940	Lockwasher — Split 7/16				1	1	1	1	1	1
	27	950	Washer 1" O.D. x 7/16 I.D. x 3/16 THK.	1	1	1	1	1	1	1	1	1
	28	951	Internal & External — Lockwasher	1	1	1	1	1	1	1	1	1
	29	915	Key For Fan 1/4 x 1/4 x 2" lg.	1	1	1	1	1	1	1	1	1
(17)	30	928	Wing Nut 5/16-18	1	1	1	1	1	1	1	1	1
(16)	31	927	Intake Guard — Clamp	1	1	1	1	1	1	1	1	1
	32	968	Bracket Eng. To Housing 5 H.P.	1	1	1						
	32	969	Bracket Eng. To Housing 8 H.P.				1	1	1	1	1	1
	32	969-11	Bracket Eng. To Housing 11 H.P.							1	1	1
	32	981	Bracket Eng. To Housing 8 H.P. KOH.							1	1	1
(3)	33	114C	Lock Nut 5/16-18	3	4	4	4	4	4	4	4	4
(8)	34	972	Lock Nut 1/4-20	5	5	5	5	5	5	5	5	5
	35	945	Throttle	1	1	1	1	1	1	1	1	1
(9)	36	378	Hex Head Cap Screw 1/4-20 x 1 1/2	1	1	1	1	1	1	1	1	1
(6)	37	917	Upper Handle	1	1	1	1	1	1	1	1	1
(2)	38	113	Hex Head Cap Screw 5/16-18 x 1 1/2	3	4	4	4	4	4	4	4	4
(10)	39	946	Throttle Clip	1	1	1	1	1	1	1	1	1
(5)	40	971	Handle Brace "V"		1	1						
(5)	40	965	Handle Brace "V"				1	1	1	1	1	1
(5)	40	957	Handle Brace "V"							1	1	1
(5)	41	918	Handle Brace — Straight	1								
(7)	42	144-1	Hex Head Cap Screw 1/4-20 x 1 1/4	4	4	4	4	4	4	4	4	4
	43	312	Retaining Ring	2	2	2	2	2	2	2	2	2
	44	933-1	10" Semi-Pneumatic Wheel	2			2					
	44	934-1	10" Pneumatic Wheel		2	2		2	2	2	2	2
	45	405-1	Washer — Light 5/8 I.D.	4			4					
	45	405	Washer — Heavy 5/8 I.D.		1	1		1	1	1	1	1
(1a)	46	916-1	Handle Support	2	2	2	2	2	2	2	2	2
(1)	47	916	Lower Handle	1	1	1	1	1	1	1	1	1
	48	932-1	Axle		1	1		1	1	1	1	1
	48	932-2	Axle	1			1					
	49	129D	Lockwasher 5/16	4	4	4	4	4	4	4	4	4
	50	942	Hex Head Cap Screw 5/16-18 x 1 3/4"	4	4	4	4	4	4	4	4	4
	50	980	Hex Head Cap Screw 3/8-16 X 2"							4	4	4
	51	976	Fan Spacer Washer							1	1	1
	52	977	Engine Pad							8	8	8
		947	Engine 5 H.P. Briggs & Stratton	1	1							
		947-1C	Engine 5 H.P. I.C. Briggs & Stratton			1						
		948	Engine 8 H.P. Briggs & Stratton					1				
		948-1C	Engine 8 H.P. I.C. Briggs & Stratton						1			
		948-11	Engine 11 H.P. Briggs & Stratton									
		948-11 I.C.	Engine 11 H.P. I.C. Briggs & Stratton									
		949	Engine 8 H.P. Kohler									

NOT ILLUSTRATED