

# LITTLE WONDER®

## Instructions and Repair Parts List for Electric Hedge Trimmers

### SINGLE EDGE MODELS:

- Cat. No. 1600SE - 16", 120v Hedge Trimmer
- Cat. No. 1602SE - 16", 220/240v Hedge Trimmer
- Cat. No. 2400SE - 24", 120v Hedge Trimmer
- Cat. No. 2402SE - 24", 220/240v Hedge Trimmer
- Cat. No. 3000SE - 30", 120v Hedge Trimmer
- Cat. No. 3002SE - 30", 220/240v Hedge Trimmer

### DOUBLE EDGE MODELS:

- Cat. No. 1600DE - 16", 120v Hedge Trimmer
- Cat. No. 1602DE - 16", 220/240v Hedge Trimmer
- Cat. No. 2400DE - 24", 120v Hedge Trimmer
- Cat. No. 2402DE - 24", 220/240v Hedge Trimmer



**WARNING**





**TO GUARD AGAINST INJURY, BASIC SAFETY PRECAUTIONS SHOULD BE OBSERVED, INCLUDING THE FOLLOWING:**

### CARE AND SAFETY

#### 1. READ AND FOLLOW ALL INSTRUCTIONS

2. **ALWAYS DRESS PROPERLY.** Do not wear loose clothing or jewelry, they might get caught in moving parts. Use sturdy properly fitting, non-slip gloves. Gloves reduce the transmission of vibration to your hands. Prolonged exposure to vibration can cause numbness and other ailments. Wear non-skid footwear to ensure secure and proper footing.

3. **STAY ALERT** — Watch what you are doing and use common sense. Do not operate trimmer when fatigued.

4.  **DANGER**  - **CUT HAZARD - KEEP HANDS AWAY FROM BLADES** - Keep both hands on handles when power is on. Do not attempt to remove cut material or hold material to be cut when blades are moving. Make sure trimmer switches are off (not depressed), the blades have stopped moving, and the unit is unplugged when clearing jammed material from blades. Do not grasp the exposed cutting blades or cutting edges of trimmer. These trimmers have been designed so they can only be operated when using both hands. Do not attempt to override this important safety feature in any way.

 **DANGER — BLADES WILL COAST AFTER UNIT HAS BEEN TURNED OFF.** 

5. **WARNING — GUARD AGAINST ELECTRIC SHOCK HAZARD** — Don't use trimmer in rain, in wet locations, or on wet hedges or shrubbery. Use only extension cords marked "suitable for use with outdoor appliances" having electrical rating not less than rating of trimmer. Examine cord regularly; if damaged, replace immediately. Do not use damaged extension cords. Inspect cords periodically and replace if damaged. Do not abuse cord. Never carry trimmer by cord. Do not yank cord to disconnect from receptacles. Keep cord away from heat, oil and sharp edges.

6. **ALWAYS KEEP A SAFE DISTANCE** between two or more operators when working together simultaneously.

7. **KEEP CHILDREN AWAY** — Do not permit children to contact trimmer or extension cord. Keep children a safe distance from work area.

8. **USE TRIMMER PROPERLY** — Use only for trimming the type of shrub, growth, etc., described in the operating instructions. Do not abuse trimmer.

9. **DON'T OVERREACH OR STAND ON UNSTABLE SUPPORT.** Do not stand on the top of a ladder while trimming. Use proper equipment for reaching higher heights. Keep a good footing at all times.

10. **AVOID UNINTENTIONAL STARTING OF TRIMMER** Before plugging in trimmer, be sure trimmer switches are off (not depressed). Keep fingers and thumb away from switches.

11. **DISCONNECT (UNPLUG) TRIMMER FROM POWER SUPPLY** — When not in use or before servicing, cleaning, etc.

12. **MAINTAIN TRIMMER WITH CARE** — Follow maintenance instructions given in manual.

13. **STORE TRIMMER INDOORS** — When not in use, store trimmer indoors in a dry place, where not accessible to children.

14. **DO NOT ATTEMPT TO REPAIR TRIMMER** — Have repairs made by qualified dealer or repairman. See that only original equipment **Little Wonder** parts are used.

15. Before each use, inspect all handles, safety devices and fasteners to be sure they are secure and in place.

# LIMITED SERVICE & WARRANTY POLICY

All **LITTLE WONDER** Electric Hedge Trimmers are guaranteed against defects in material and workmanship for a period of TWO YEARS from date of purchase when used for RESIDENTIAL SERVICE, or ONE YEAR from date of purchase when used for COMMERCIAL SERVICE. Any **LITTLE WONDER** Electric Hedge Trimmer or part found to be defective within the warranty period is to be returned to any registered **LITTLE WONDER** dealer.

Transportation charges for parts and units submitted for replacement under this warranty must be borne by the purchaser.

THIS WARRANTY shall not be effective if the product has been subject to misuse, negligence or accident, used in cutting hedges or shrubs greater than 1/2" in diameter, used to cut foreign objects such as wire, rocks, or fences, or if the product has been repaired or altered outside of our Southampton factory, or any registered **LITTLE WONDER** dealer, in any respect which affects its condition or operation.

**LITTLE WONDER** shall not be liable for any special indirect or consequential damages arising from defective equipment. Any implied warranty, including merchantability of fitness for a particular purpose, shall not extend beyond the written warranty period.

THIS WARRANTY shall only be effective if the enclosed Warranty/Registration card is properly filled out and returned to **LITTLE WONDER**, Div. of Schiller-Pfeiffer, Inc. at time of purchase.

Specifications, descriptions, and illustrative material in this literature are as accurate as known at the time of publication, but are subject to change without notice.

# **LITTLE WONDER®**

DIVISION OF SCHILLER-PFEIFFER, INCORPORATED

P.O. Box 38, 1028 Street Road  
Southampton, PA 18966 USA

Phone: 215-357-5110

Fax: 215-357-8045

## Single Edge Trimmer Assembly

Before using the hedge trimmer, mount the side handles. Push handle into openings provided and install (2) allen head screws as shown.

Caution! When pushing the handles into position, do not squeeze the white switch button!

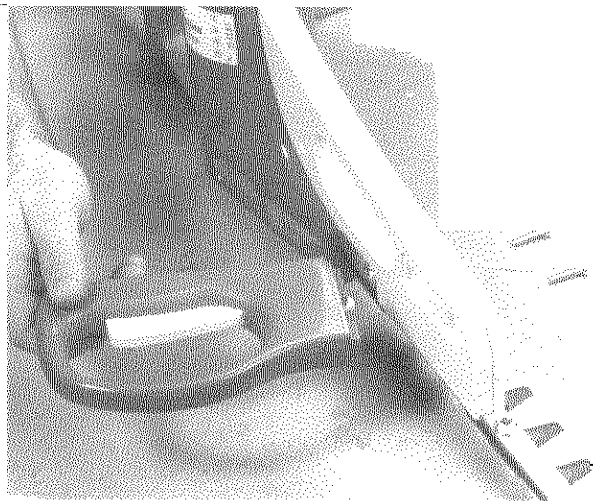

Push the allen head screws into their openings, and tighten them with wrench provided.

Test the switch. If trigger does not operate the switch freely, repeat the assembly procedure.

## Blade Adjustment



**WARNING**



ALWAYS DISCONNECT THE PLUG FROM THE POWER SOURCE BEFORE STARTING WORK

The care and adjustment of the blades is very important to the efficient operation of the trimmer and especially to the long life of the motor.

1. Place trimmer in vise, clamping on the frame bar. Be careful! Blades are sharp!

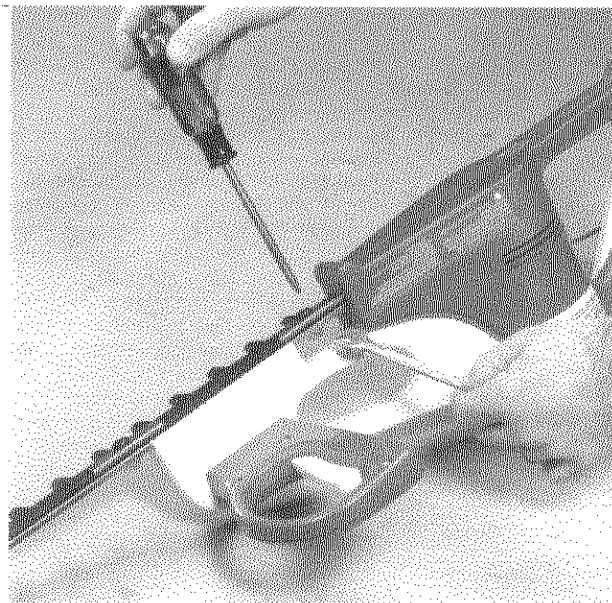

Single Edged Trimmer Shown

2. Using a 7/16" wrench, loosen all blade locknuts and unscrew the large head screws by two turns.

3. Starting with the screw nearest the gear housing, tighten the screw until the blade guard of the Single Edged trimmer or the protective comb of the Double Edged trimmer can just be moved with finger pressure and a .0015" (1 1/2 thou.) feeler blade just slips under the blade guard or comb. Tighten the locknuts while holding the screw stationary in its correct adjusted position.

4. Repeat Step 3 on the screws in turn until all are correctly adjusted.

**NOTE: CORRECT BLADE ADJUSTMENT CAN ONLY BE ACHIEVED ON CLEAN, OILED BLADES.**

# SINGLE EDGE TRIMMER REPLACEMENT PARTS

Specify by Part Number  
Do Not order by Key Number

KEY NO.	PART NUMBER	DESCRIPTION	QUANTITY PER CAT. NO.					
			1602SE	1600SE	2400SE	2402SE	3000SE	3002SE
1	16-54A	Large head screw 1/4 - 28 x 3/4"	3	3	4	4	5	5
2	16-57A	Cover plate	1	1	1	1	1	1
3	D16-71	Gasket	1	1	1	1	1	1
4	16-55	Flat head screw 1/4 - 28 x 1/2"	2	2	2	2	2	2
5	16-64	Connecting rod	1	1	1	1	1	1
6	16-65	Connecting rod spacer	1	1	1	1	1	1
7	16-62	Eccentric gear	1	1	1	1	1	1
8	16-67	Felt	1	1	1	1	1	1
9	D16-59	Cluster gear	1	1	1	1	1	1
10	D16-56F	Wear plate	1	1	1	1	1	1
11	3027	Gear housing with shafts and screws	1	1	1	1	1	1
11D	16-81	Cover plate screw #6-32 x 5/16 (set of 8)	8	8	8	8	8	8
12	16-69D	Bearing	1	1	1	1	1	1
13	16-93	Blade guard	3	3	4	4	5	5
14	16-51	Outside blade assy.	1	1	—	—	—	—
14	24-1	Outside blade assy.	—	—	1	1	—	—
14	30-1	Outside blade assy.	—	—	—	—	1	1
15	16-52	Inside blade assy.	1	1	—	—	—	—
15	24-2	Inside blade assy.	—	—	1	1	—	—
15	30-2	Inside blade assy.	—	—	—	—	1	1
16	16-53-2	Frame bar assy.	1	1	—	—	—	—
16	24-3-1	Frame bar assy.	—	—	1	1	—	—
16	30-3-1	Frame bar assy.	—	—	—	—	1	1
17	16-54B	Nut-lock flange 1/4-28	3	3	4	4	5	5
18	3036	Nut-lock 1/4-28	2	2	2	2	2	2
19	3000	Armature 24" & 30" 220V	—	—	—	1	—	1
19	3002	Armature 16" 220V	—	1	—	—	—	—
19	3004	Armature 24" & 30" 120V	—	—	1	—	1	—
19	3006	Armature 16" 120V	1	—	—	—	—	—
20	D16-72B	Strain relief	1	—	1	—	1	—
20	D16-220-72B	Strain relief	—	1	—	1	—	1
21	16-69E	Bearing	1	1	1	1	1	1
22	3023	Motor housing base	1	1	1	1	1	1
23	3042	Round head machine screw 8-32 x 1"	2	2	2	2	2	2
24	3001	Field, 24" & 30" 220V	—	—	—	1	—	1
24	3003	Field, 16" 220V	—	1	—	—	—	—
24	3005	Field, 24" & 30" 120V	—	—	1	—	1	—
24	3007	Field, 16" 120V	1	—	—	—	—	—
24A	3028	Condenser (220V only)	—	1	—	1	—	1
24B	3026	Brush retainer	2	2	2	2	2	2
25	3024	Motor housing cap	1	1	1	1	1	1
26	3044	Motor tie bolt 8032 x 1 7/8"	2	2	—	—	—	—
26	3043	Motor tie bolt 8-32 x 2 1/4"	—	—	2	2	2	2
27	3035	Brush-motor	2	2	2	2	2	2
28	3039	Phillips pan head self-tapping screw B4.2 x 16" DIN 7981	9	9	9	9	9	9
29	3012	Side handle - bottom	1	1	1	1	1	1
30	3013	Side handle - top	1	1	1	1	1	1
31	3037	Nut M6 x 25 DIN 912-88	2	2	2	2	2	2
32	3014	Trigger - side handle	1	1	1	1	1	1
33	3010	Lift handle - right	1	1	1	1	1	1
34	3011	Lift handle - left	1	1	1	1	1	1
35	3033	Switch	2	2	2	2	2	2
36	3038	Socket head cap screw M6 x 25 x 8.3 DIN 912	2	2	2	2	2	2
37	3040	Phillips pan head self-tapping screw B4.2 x 25.0 DIN 7981	4	4	4	4	4	4
38	3041	Phillips pan head self-tapping screw B3.5 x 13.0 DIN 7981	2	2	2	2	2	2
39	3017	Spring	2	2	2	2	2	2
40	3008	Main housing - right	1	1	1	1	1	1
41	3009	Main housing - left	1	1	1	1	1	1
42	3015	Trigger - housing	1	1	1	1	1	1
43	3016	Cable clamp	—	1	—	1	—	1
44	3031	Wire lead with connector - 6 1/4" short (220V only)	—	1	—	1	—	1
45	3050	Connector blocks (2)	—	1	—	1	—	1
46	3025	Brush holder	2	2	2	2	2	2
47	3060	Cord 102V w/connectors	1	—	1	—	1	—
47	D16-220-72	Cord 220V	—	1	—	1	—	1
1 & 17	16-54	Screw (16-54A) with nut (16-54B)	—	1	—	1	—	1
48 & 24A	3000M	220V, 1/5 HP Motor, incl. housing, armature, field, field tie bolts, bearings, brushes, brush holders, brush retainers and condenser.	—	—	—	—	—	—
48 & 24A	3002M	220V, 1/10 HP Motor, incl. housing, armature, field, field tie bolts, bearings, brushes, brush holders, brush retainers and condenser.	—	—	—	—	—	—
48	3004M	120V, 1/5 HP Motor, incl. housing, armature, field, field tie bolts, bearings, brushes, brush holders and brush retainers.	—	—	—	—	—	—
48	3006M	120V, 1/10 HP Motor, incl. housing, armature, field, field tie bolts, bearings, brushes, brush holders and brush retainers. 1600SE only	—	—	—	—	—	—
	3064	Wrench M6 (not illustrated)	—	—	—	—	—	—
40 & 41	3032	Main housing set	—	—	—	—	—	—
33 & 34	3029	Lift handle set	—	—	—	—	—	—
22,25,46	3067	Motor housing base and cap w/brush holders (3)	—	—	—	—	—	—

**DO NOT ATTEMPT TO REPAIR TRIMMER** — Have repairs made by qualified dealer or repairman. See that only **Little Wonder** replacement parts are used. All parts listed must be ordered through your local dealer or distributor. When ordering repair parts, always specify the catalog number of the product.



# SINGLE EDGE TRIMMER REPLACEMENT PARTS

Specify by Part Number  
Do Not order by Key Number

KEY NO.	PART NUMBER	DESCRIPTION	QUANTITY PER CAT. NO.					
			1602SE	1600SE	2400SE	2402SE	3000SE	3002SE
1	16-54A	Large head screw 1/4 - 28 x 3/4"	3	3	4	4	5	5
2	16-57A	Cover plate	1	1	1	1	1	1
3	D16-71	Gasket	1	1	1	1	1	1
4	16-55	Flat head screw 1/4 - 28 x 1/2"	2	2	2	2	2	2
5	16-64	Connecting rod	1	1	1	1	1	1
6	16-65	Connecting rod spacer	1	1	1	1	1	1
7	16-62	Eccentric gear	1	1	1	1	1	1
8	16-67	Felt	1	1	1	1	1	1
9	D16-59	Cluster gear	1	1	1	1	1	1
10	D16-56F	Wear plate	1	1	1	1	1	1
11	3027	Gear housing with shafts and screws	1	1	1	1	1	1
11D	16-81	Cover plate screw #6-32 x 5/16 (set of 8)	8	8	8	8	8	8
12	16-69D	Bearing	1	1	1	1	1	1
13	16-93	Blade guard	3	3	4	4	5	5
14	16-51	Outside blade assy.	1	1	—	—	—	—
14	24-1	Outside blade assy.	—	—	1	1	—	—
14	30-1	Outside blade assy.	—	—	—	—	1	1
15	16-52	Inside blade assy.	1	1	—	—	—	—
15	24-2	Inside blade assy.	—	—	1	1	—	—
15	30-2	Inside blade assy.	—	—	—	—	1	1
16	16-53-2	Frame bar assy.	1	1	—	—	—	—
16	24-3-1	Frame bar assy.	—	—	1	1	—	—
16	30-3-1	Frame bar assy.	—	—	—	—	1	1
17	16-54B	Nut-lock flange 1/4-28	3	3	4	4	5	5
18	3036	Nut-lock 1/4-28	2	2	2	2	2	2
19	3000	Armature 24" & 30" 220V	—	—	—	1	—	1
19	3002	Armature 16" 220V	—	1	—	—	—	—
19	3004	Armature 24" & 30" 120V	—	—	1	—	1	—
19	3006	Armature 16" 120V	1	—	—	—	—	—
20	D16-72B	Strain relief	1	—	1	—	1	—
20	D16-220-72B	Strain relief	—	1	—	1	—	1
21	16-69E	Bearing	1	1	1	1	1	1
22	3023	Motor housing base	1	1	1	1	1	1
23	3042	Round head machine screw 8-32 x 1"	2	2	2	2	2	2
24	3001	Field, 24" & 30" 220V	—	—	—	1	—	1
24	3003	Field, 16" 220V	—	1	—	—	—	—
24	3005	Field, 24" & 30" 120V	—	—	1	—	1	—
24	3007	Field, 16" 120V	1	—	—	—	—	—
24A	3028	Condenser (220V only)	—	1	—	1	—	1
24B	3026	Brush retainer	2	2	2	2	2	2
25	3024	Motor housing cap	1	1	1	1	1	1
26	3044	Motor tie bolt 8032 x 1 7/8"	2	2	—	—	—	—
26	3043	Motor tie bolt 8-32 x 2 1/4"	—	—	2	2	2	2
27	3035	Brush-motor	2	2	2	2	2	2
28	3039	Phillips pan head self-tapping screw B4.2 x 16" DIN 7981	9	9	9	9	9	9
29	3012	Side handle - bottom	1	1	1	1	1	1
30	3013	Side handle - top	1	1	1	1	1	1
31	3037	Nut M6 x 25 DIN 912-88	2	2	2	2	2	2
32	3014	Trigger - side handle	1	1	1	1	1	1
33	3010	Lift handle - right	1	1	1	1	1	1
34	3011	Lift handle - left	1	1	1	1	1	1
35	3033	Switch	2	2	2	2	2	2
36	3038	Socket head cap screw M6 x 25 x 8.3 DIN 912	2	2	2	2	2	2
37	3040	Phillips pan head self-tapping screw B4.2 x 25.0 DIN 7981	4	4	4	4	4	4
38	3041	Phillips pan head self-tapping screw B3.5 x 13.0 DIN 7981	2	2	2	2	2	2
39	3017	Spring	2	2	2	2	2	2
40	3008	Main housing - right	1	1	1	1	1	1
41	3009	Main housing - left	1	1	1	1	1	1
42	3015	Trigger - housing	1	1	1	1	1	1
43	3016	Cable clamp	—	1	—	1	—	1
44	3031	Wire lead with connector - 6 1/4" short (220V only)	—	1	—	1	—	1
45	3050	Connector blocks (2)	—	1	—	1	—	1
46	3025	Brush holder	2	2	2	2	2	2
47	3060	Cord 102V w/connectors	1	—	1	—	1	—
47	D16-220-72	Cord 220V	—	1	—	1	—	1
1 & 17	16-54	Screw (16-54A) with nut (16-54B)	—	1	—	1	—	1
48 & 24A	3000M	220V, 1/5 HP Motor, incl. housing, armature, field, field tie bolts, bearings, brushes, brush holders, brush retainers and condenser.	—	—	—	—	—	—
48 & 24A	3002M	220V, 1/10 HP Motor, incl. housing, armature, field, field tie bolts, bearings, brushes, brush holders, brush retainers and condenser.	—	—	—	—	—	—
48	3004M	120V, 1/5 HP Motor, incl. housing, armature, field, field tie bolts, bearings, brushes, brush holders and brush retainers.	—	—	—	—	—	—
48	3006M	120V, 1/10 HP Motor, incl. housing, armature, field, field tie bolts, bearings, brushes, brush holders and brush retainers. 1600SE only	—	—	—	—	—	—
	3064	Wrench M6 (not illustrated)	—	—	—	—	—	—
40 & 41	3032	Main housing set	—	—	—	—	—	—
33 & 34	3029	Lift handle set	—	—	—	—	—	—
22,25,46	3067	Motor housing base and cap w/brush holders (3)	—	—	—	—	—	—

**DO NOT ATTEMPT TO REPAIR TRIMMER** — Have repairs made by qualified dealer or repairman. See that only **Little Wonder** replacement parts are used. All parts listed must be ordered through your local dealer or distributor. When ordering repair parts, always specify the catalog number of the product.



# DOUBLE EDGE TRIMMER REPLACEMENT PARTS

Specify by Part Number  
Do Not order by Key Number

KEY NO.	PART NUMBER	QUANTITY PER CAT. NO.		
		1602DE	2400DE	2402DE
1	16-54A	3	4	4
2	16-57A			1
3	D16-71		1	1
4	16-55	2	2	2
5	16-64			1
6	16-65		1	1
7	16-62		1	1
8	16-67		1	1
9	D16-59		1	1
10	D16-56F		1	
11	3027	1	1	1
11D	16-81	8	8	8
12	16-69D		1	
13	16-42		1	1
13	24-24		1	1
14	16-51D	1		
14	24-1D			
15	16-52D	1		
15	24-2D			
16	16-53	1		
16	24-3		1	
17	16-54B	3	4	4
18	3066	1	1	
19	3000			
19	3002	1		
19	3004		1	
19	3006			
20	D16-72B		1	
20	D16-220-72B	1		
21	16-69E	1		
22	3023	1	1	
23	3042	2	2	2
24	3001			1
24	3003	1		
24	3005			
24	3007			
24A	3028	1		1
24B	3026	2	2	2
25	3024	1		
26	3044	2		
26	3043	2	2	2
27	3035	2	2	2
28	3039	3	3	3
29	3020A	1	1	
30	3021A	1		
31	3022A			
32	3018	1		
33	3019	1		
34	3069A	1		
35	3033	2	2	2
36	3068	1	1	
37	3040	4	4	4
38	3041	2	2	2
39	3017	1		
40	3008	1		
41	3009	1		
42	3015	1		
43	3016	1		
44	3030	1		
45	3031	1		
46	3050	1		
47	3025	2		
48	3060		2	2
48	D16-220-72			
1 & 17	16-54			
49 & 24A	3000M			
49 & 24A	3002M			
49	3006M			
	3065			
40 & 41	3032			
32, 33, 34	3045			
22, 25, 47	3067			



# DOUBLE EDGE TRIMMER REPLACEMENT PARTS

Specify by Part Number  
Do Not order by Key Number

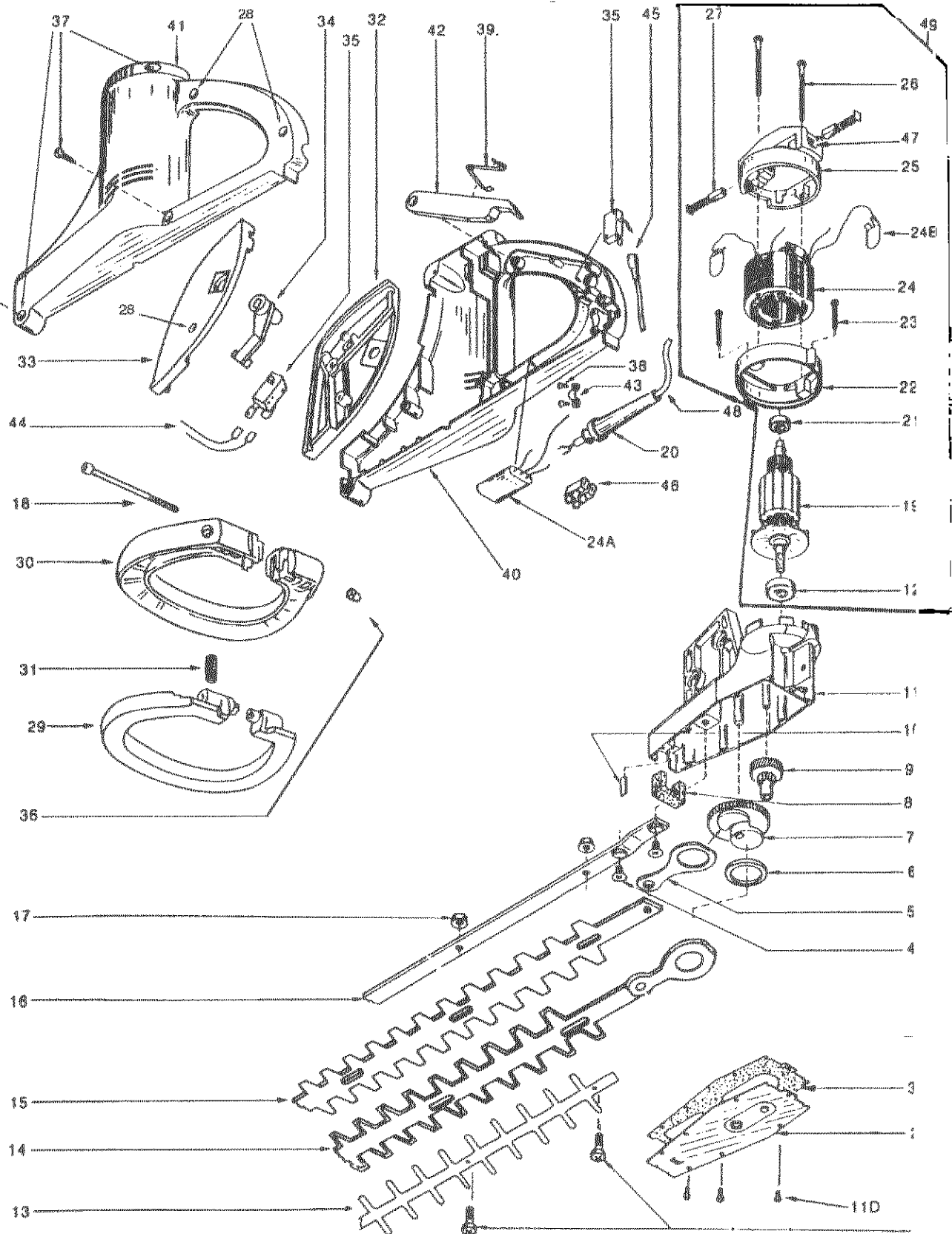

**DO NOT ATTEMPT TO REPAIR TRIMMER** - Have repairs made by qualified dealer or repairmen. See that only **LITTLE WONDER** replacement parts are used. All parts listed may be ordered through your local dealer or distributor. When ordering repair parts, always specify parts by the catalog number

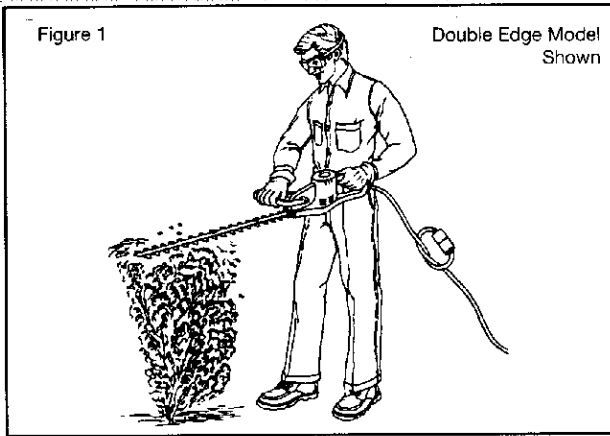

1. READ CARE AND SAFETY INSTRUCTIONS CAREFULLY.
2. Before plugging into an electric circuit, be sure that the voltage supply is as specified on hedge trimmer.
3. Be sure the switches are in the "OFF" (not depressed) position before connecting unit to the applicable current. **(120V AC or 220V/240V AC.)**
4. Knot extension cord as shown in Figure #1 to prevent a disconnection when cord is pulled along the ground.
5. Keep extension cord behind trimmer. Never drape extension cord over hedge being trimmed. On 120V units, use 16 gauge wire extension cord up to 100 feet. Over 100 feet use 14 or heavier gauge wire or extension cord. Cords are available from your local Little Wonder dealer. The use of light gauge lamp cords or sizes lighter than those specified above will result in loss of power and possible motor failure.
6. **⚠ WARNING ⚠** These trimmers have been designed so they can only be operated when using both hands. Do not attempt to override this important safety feature in any way.
7. Hold trimmer firmly. For Single Edge Model, keep right hand on side handle and left hand on rear handle. For Double Edge Model, you can place either hand on either handle. Squeeze both switches. Tilt trimmer so cutting tooth is angled slightly toward the hedge or shrub and proceed to cut. The unit is designed to cut any type of hedge or shrub; however,
 

THICKNESS OF CUT SHOULD NOT EXCEED 1/2 INCH IN DIAMETER.

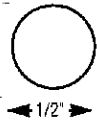

*Misuse of this Hedge Trimmer will void the warranty.*  
 ie: Cutting hedges or shrubs over 1/2" in diameter or foreign objects such as wires, rocks, or fences. Before trimming check work area for foreign objects such as wires, cords, glass, fences, or rocks. Be sure to remove any foreign objects from the work area. Failure to properly maintain this hedge trimmer will void the warranty.

1. A few drops of light (#10) oil should be placed at each adjusting screw approximately every four hours of normal operation.
2. To obtain trouble free trimming, it is necessary to keep the blades lubricated and clean. The gum that collects and builds up on the blades can be removed with a 50-50 mixture of kerosene and #10 oil. As a petroleum products can shorten the life of some plastics it is necessary to remove excess oil-kerosene mixture from the plastic parts. **Blades must be clean before they can be adjusted.**
3. A few drops of light (#10) or 3-in-1 oil should be put in the hole indicated on the bottom main housing. This is only necessary at the beginning of a day's operation.
4. Gear housing and motor bearings have been permanently lubricated with a special grease which should last for the life of the trimmer. When blades are replaced, or any other time that the bottom cover plate is removed, the grease must be checked for proper amount and a new gasket must be used to insure proper seating of cover plate. Use only Lubrico M3-3K-9K grease (P/N 16-78A) in the gear housing. Lubrico M24M (P/N 16-78B) is to be used on the motor bearings. Lubrico is available thru your local **Little Wonder** Dealer.
5. Before each use, inspect to be sure handles, safety devices and fasteners are secure and in place.