

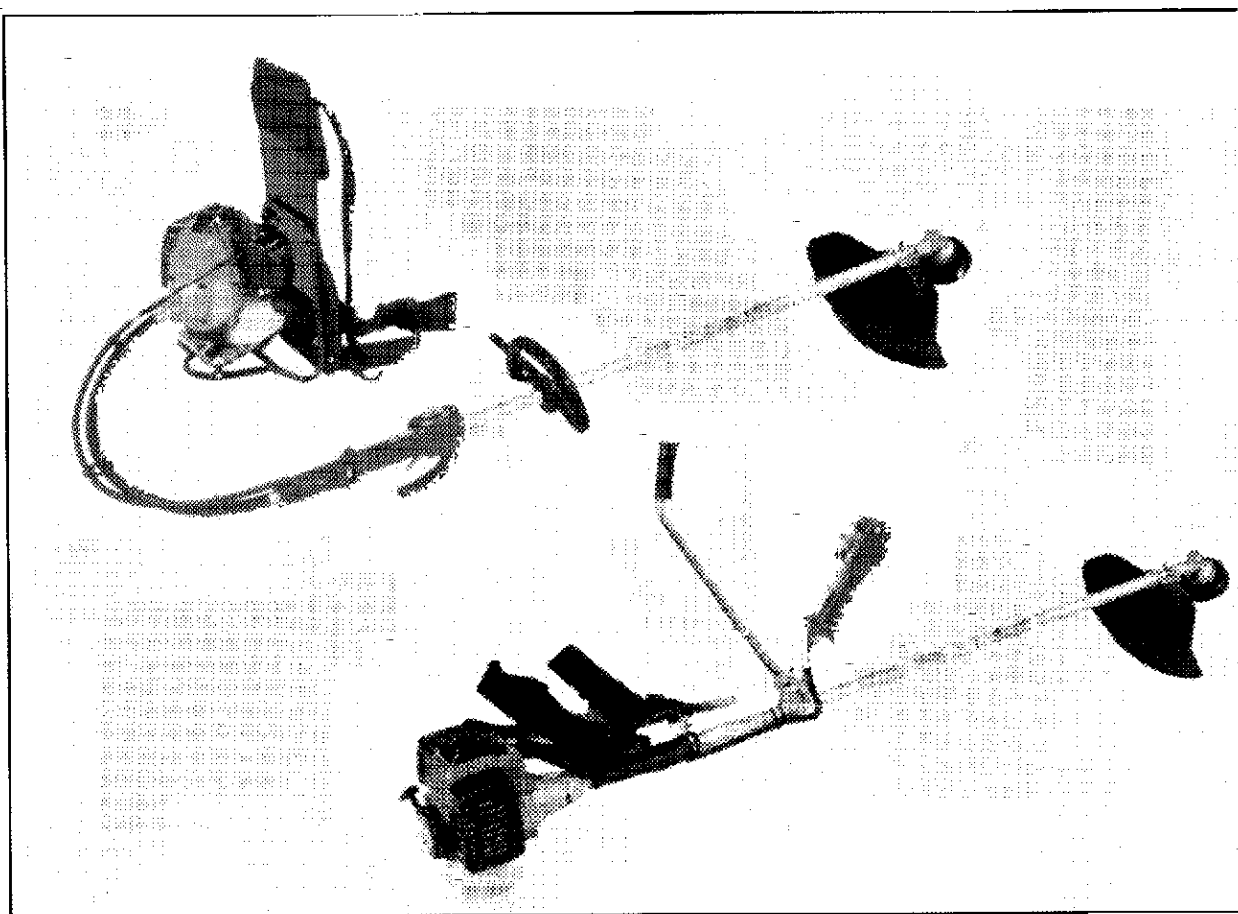

Stampato nr. / Form no.
Imprimé no. / Drucksachen Nr.
P5090272

**LISTA RICAMBI
SPARE PARTS LIST
LISTE DES PIÈCES DE RECHANGE
ERSATZTEILLISTE**



**DECESPUGLIATORE
BRUSH CUTTER
DÉBROUSSAILLEUSE
FREISCHNEIDER**

MBC 430/430 D/430 K

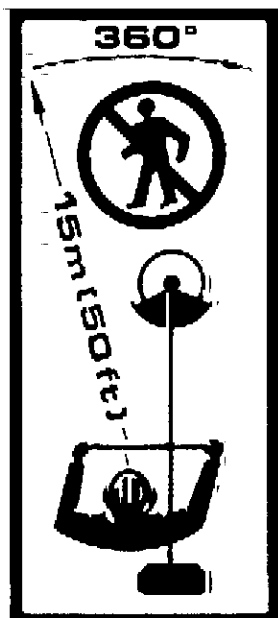

1



2

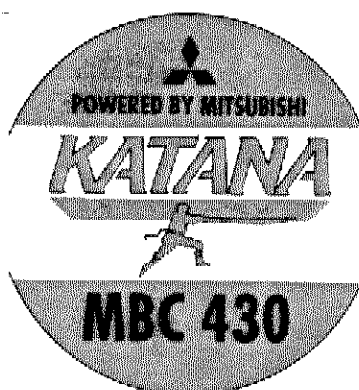

3

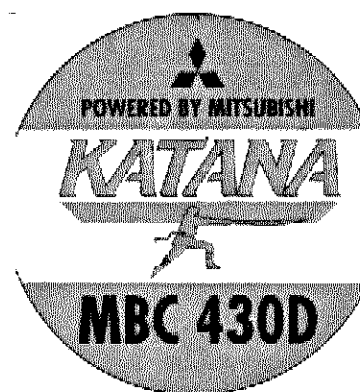

4



5

Nr.	Cod.	Q.ty	Descrizione	Description	Description	Beschreibung
1	P920-37504-200		Decalcomania	Decal	Autocollant	Abziehbild
2	P5140708		Decalcomania	Decal	Autocollant	Abziehbild
3	P5140705		Decalcomania	Decal	Autocollant	Abziehbild
4	P5140706		Decalcomania	Decal	Autocollant	Abziehbild
5	P5140707		Decalcomania	Decal	Autocollant	Abziehbild
	P5110018		Chiave a brugola 4	Allen wrench 4	Clé 4	Schlüssel 4
	P5110019		Chiave fissa 8/10	Wrench 8/10	Clé 8/10	Schlüssel 8/10
	P5110020		Chiave 17/19	Spanner 17/19	Clé 17/19	Schlüssel 17/19

2 - CILINDRO
 2 - CYLINDER
 2 - CYLINDRE
 2 - ZYLINDER

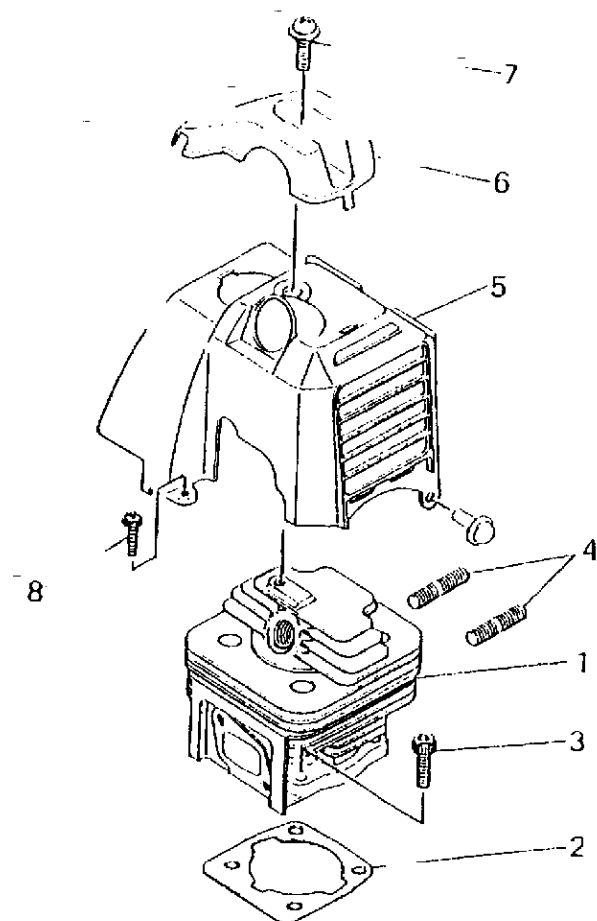

Nr.	Cod.	Q.ty	Descrizione	Description	Description	Beschreibung
1	MKC13010AA	1	Cilindro	Cylinder	Cylindre	Zylinder
2	MKW32011AA	1	Guarnizione cilindro	Gasket, cylinder	Joint	Dichtscheibe
3	MB121C05X020	4	Bullone	Bolt	Boulon	Schraube
4	MB151B06X050	2	Prigioniero	Bolt, stud	Goujon	Stehbolzen
5	MKH40029BA	1	Coperchio cilindro	Cover, cylinder	Couvercle	Deckel
6	MKH70009AA	1	Protezione	Guard, plug	Protection	Schutz
7	MH071D05X020K	1	Vite	Screw	Vis	Schraube
8	MKU12018BA	1	Vite	Screw	Vis	Schraube

- 3 - ALBERO MOTORE E PISTONE
- 3 - CRANKSHAFT & PISTON SYSTEM
- 3 - ARBRE MOTEUR ET PISTON
- 3 - KURBELWELLE

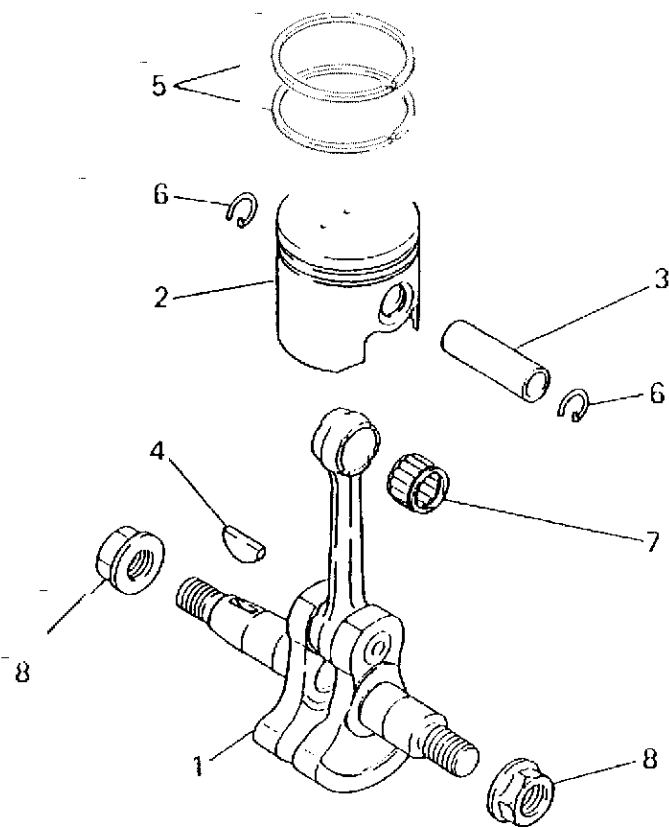

Nr.	Cod.	Q.ty	Descrizione	Description	Description
1	MKD01017CA	1	Albero motore	Crankshaft	Arbre moteur
2	MKP01029AA	1	Pistone (incl. 3)	Piston set (incl. 3)	Piston (incl. 3)
3	MFR67317	1	Spinotto	Pin, piston	Goupille
4	MW430B03X013	1	Chiavetta	Key	Axe du piston
5	MKP23004AA	2	Fascia	Ring, top	Segment du piston
6	MFR34111	2	Fermo spinotto	Clip, piston pin	Segment d'arrêt
7	MFR92523	1	Cuscinetto a rulli	Bearing, needle	Roulement
8	MZZ70028C	2	Dado	Nut, conical SPG	Écrou

- 4 - VOLANO E BOBINA
- 4 - FLYWHEEL MAGNETO SYSTEM
- 4 - VOLANT ET BOBINE
- 4 - SCHWUNGRAD

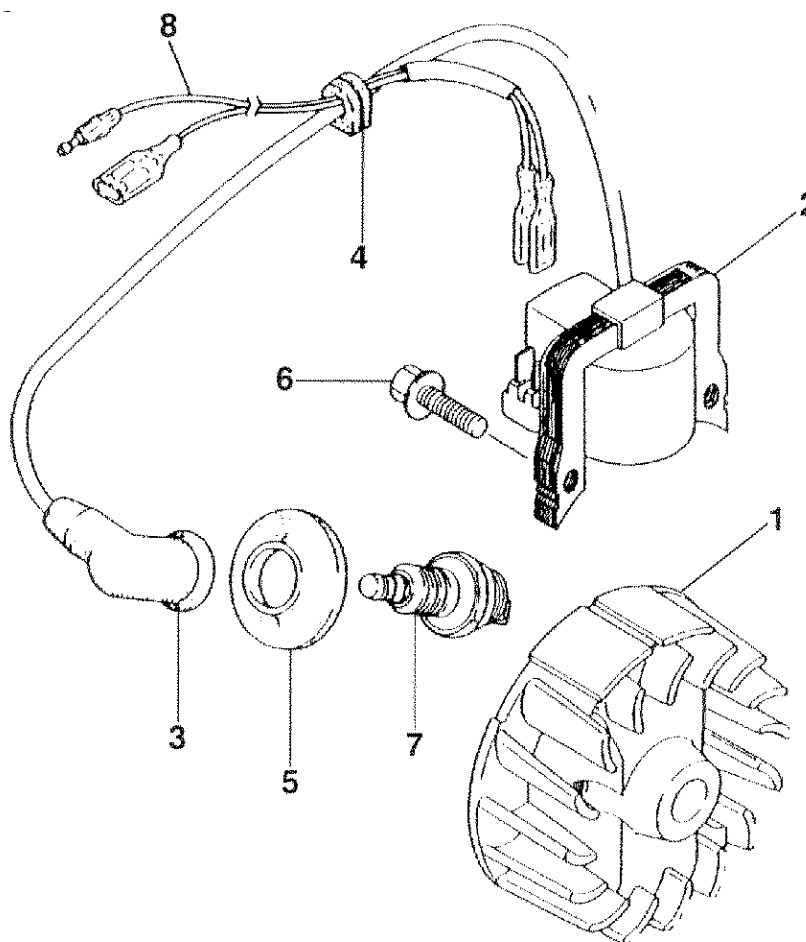

Nr.	Cod.	Q.ty	Descrizione	Description	Description	Beschreibung
1	MKE11018AA	1	Volano	Flywheel	Volant	Schwungrad
2	MKE04024AA	1	Bobina (incl. 3)	Coil, ignition (incl. 3)	Bobine (incl. 3)	Zündspule (incl. 3)
3	MFR64961	1	Cappuccio candela	Cap, plug	Capuchon de la bougie	Stecker
4	MKE90001BA	1	Gommino	Grommet	Protection	Schutz
5	MFR66751	1	Protezione	Cap, plug	Protection	Schutz
6	MFR64569A	2	Bullone	Bolt	Boulon	Schraube
7	MFR63087A	1	Candela NGK BM6A	Plug, spark NGK BM6A	Bougie NGK BM6A	Kerze NGK BM6A
8	MKE90106AA	1	Cavi	Wire, lead	Câbles	Kabel

- 5 - CARBURATORE
- 5 - CARBURETOR SYSTEM
- 5 - CARBURATEUR
- 5 - VERGASER

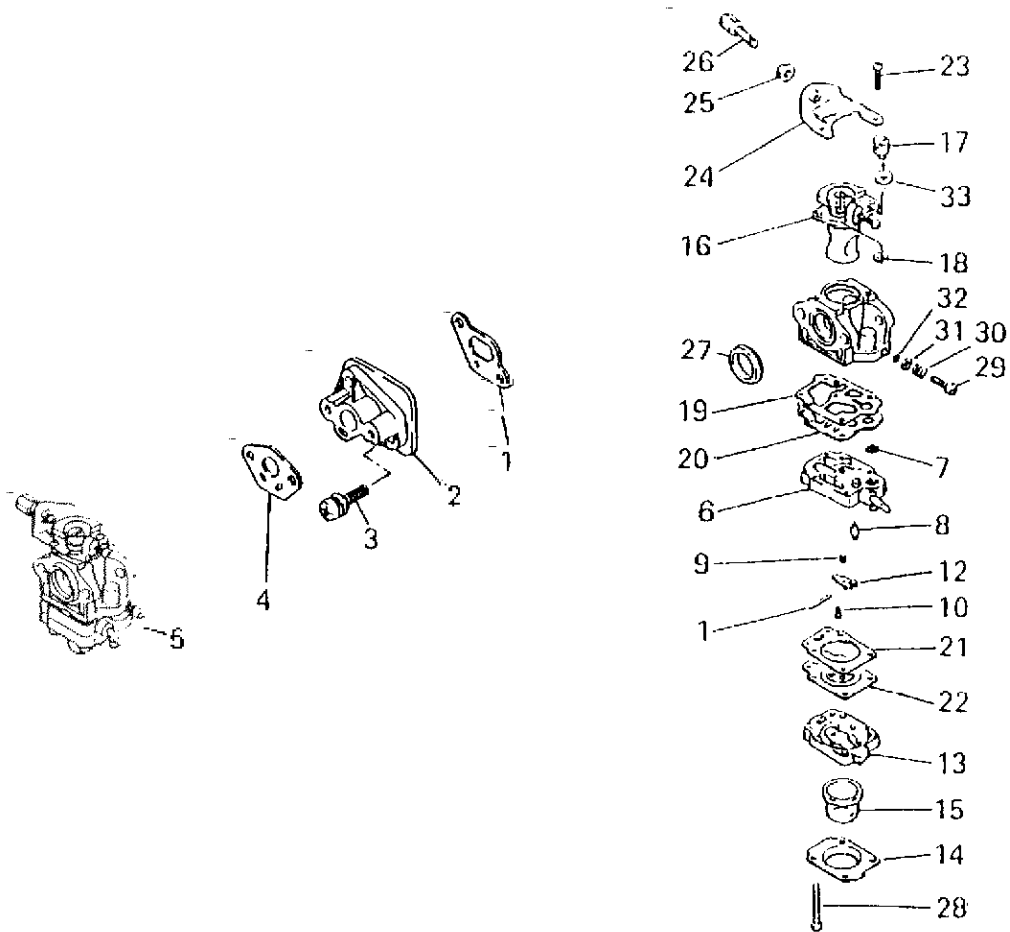

Nr.	Cod.	Q.tv	Descrizione	Description	Description	Beschreibung
	MKW34043AA		Guarnizione	Gasket	Joint	Dichtung
2	MKK31019AA		Isolatore	Insulator	Isolateur	Isolator
3	MFR64960E	2	Vite	Screw	Vis	Schraube
4	MKW39052AA		Guarnizione	Gasket	Joint	Dichtscheibe
5	MKK23002AA		Carburatore (incl.6-33)	Carburetor (incl.6-33)	Carburateur (incl. 6-33)	Vergaser (incl.6-33)
6	MKK22016AA002		Corpo pompa (incl.7-12)	Body, pump (incl. 7-12)	Corps de pompe	Körper (incl. 7-12)
7	MKK21009AA002		Filtro	Screen	Filtre	Filter
8	MKK22007AA003		Spillo	Valve, needle	Pointeau	Nadelventil
9	MKK23002AA005		Molla	Spring	Ressort	Feder
10	MKK22007AA005		Vite	Screw	Vis	Schraube
11	MFR66652XX027		Spina	Pin	Goupille	Bolzen
12	MFR66652XX029		Leva	Lever	Levier	Hebel
13	MKK22007AA006		Corpo	Body	Corps	Körper
14	MKK22007AA007		Coperchio	Cover	Couvercle	Deckel
15	MKK21017AA013		Primer	Primer pump	Pompe carburation	Pumpe
16	MKK23002AA306	1	Valvola	Valve, throttle	Vanne à papillon	Klappe
17	MKK21024AA022	1	Ferma cavo	Holder, wire	Collier	Kabelhalter
18	MFR66652XX032	1	Fermo	Clip	Collier	Halter
19	MKK21017AA004	1	Guarnizione	Gasket	Joint	Dichtscheibe
20	MKK21017AA005	1	Membrana	Diaphragm	Membrane	Membran
21	MKK22007AA012	1	Guarnizione	Gasket	Joint	Dichtscheibe
22	MFR66652XX013	1	Membrana	Diaphragm	Membrane	Membran
23	MKK21017AA021	2	Vite	Screw	Vis	Schraube
24	MKK22023AA014	1	Supporto	Bracket	Support	Lager
25	MKK21017AA027	1	Dado	Nut	Écrou	Mutter
26	MKK21017AA126	1	Vite	Screw	Vis	Schraube
27	MKK21024AA014	1	Anello	Packing	Bague	Ring
28	MKK22007AA019	4	Vite	Screw	Vis	Schraube
29	MKK23002AA019	1	Vite H	Needle, high speed (H)	Vis haute vitesse (H)	Schraube (H)
30	MKK21021AA008	1	Molla	Spring	Ressort	Feder
31	MKK22007AA022		Ranella	Washer	Rondelle	Unterlegscheibe
32	MKK22007AA023		O-ring	O-ring	Joint torique	O-ring
33	MKK22004EA024		Ranella	Washer	Rondelle	Unterlegscheibe

6 - FILTRO ARIA
 6 - AIR CLEANER SYSTEM
 6 - FILTRE À AIR
 6 - LUFTFILTER

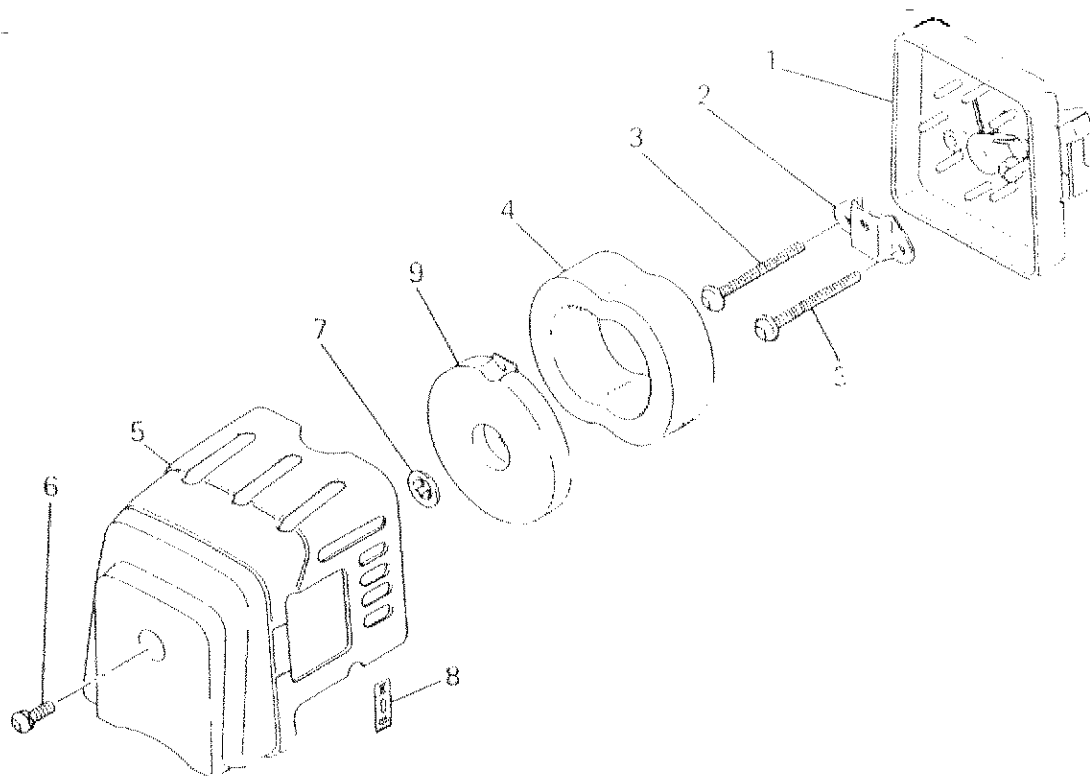

Nr.	Cod.	Q.ty	Descrizione	Description	Description	Beschreibung
1	MKA01055AA	1	Filtro aria	Air cleaner	Filtre à air	Luftfilter
2	MKA90076AA	1	Supporto	Bracket	Support	Lager
3	MH081D05X050	2	Vite	Screw	Vis	Schraube
4	MKA40046AA	1	Elemento filtro	Element, cleaner	Filtre	Filtereinsatz
5	MKA20033AA	1	Coperchio filtro	Cover, cleaner	Couvercle	Deckel
6	MH071D05X012K	1	Vite	Screw	Vis	Schraube
7	MN611K05	1	Dado	Nut	Écrou	Mutter
8	MFR67555	1	Decalcomania	Decal	Autocollant	Abziehbild
9	MKA50004AA	1	Fermo	Holder	Collier	Halter

- 7 - MARMITTA
- 7 - MUFFLER SYSTEM
- 7 - BOÎTE D'ÉCHAPPEMENT
- 7 - SCHALLDÄMPFER

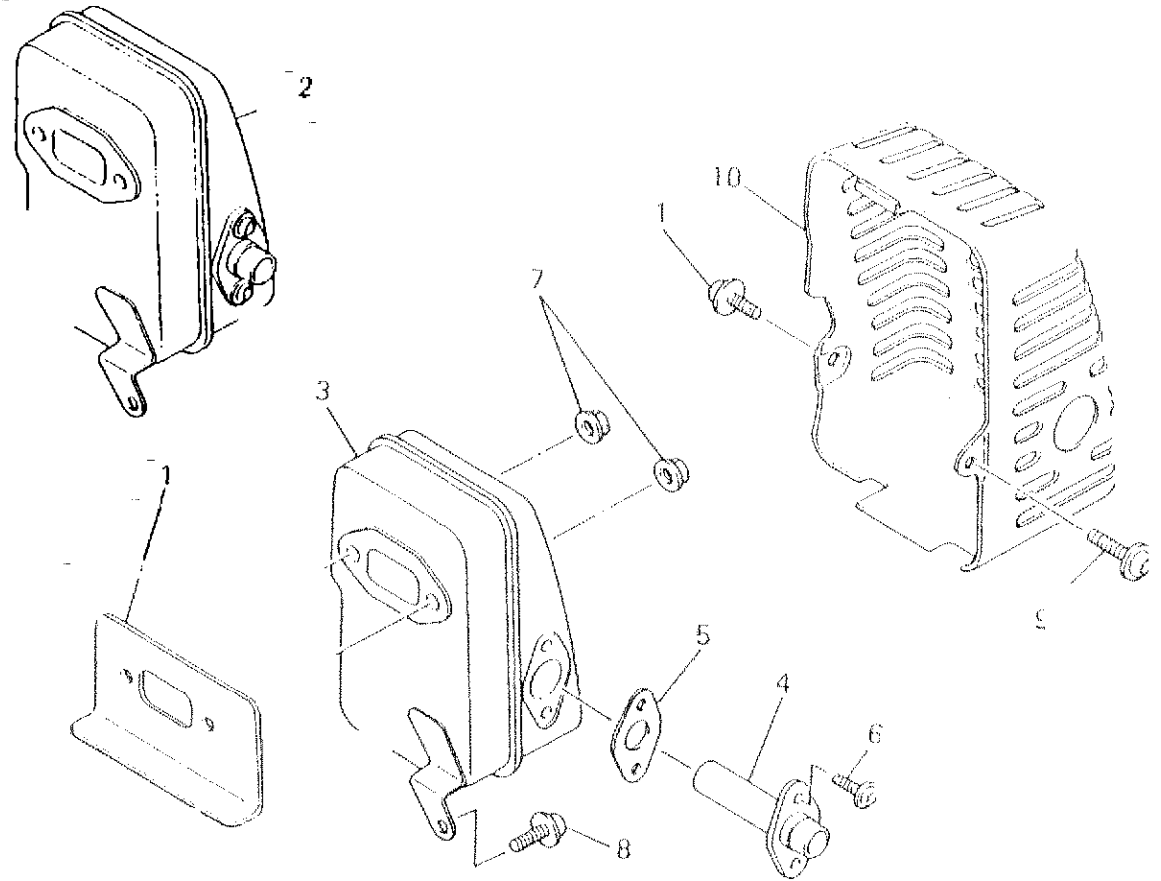

Nr.	Cod.	Q.ty	Descrizione	Description	Description	Beschreibung
1	MKM70025AA	1	Guarnizione	Gasket, muffler	Joint	Dichtscheibe
2	MKM01036AA	1	Marmitta (incl. 3-6)	Muffler (incl. 3-6)	Boîte d'échappement (incl. 3-6)	Schalldämpfer (incl. 3-6)
3	MKM01037AA	1	Marmitta	Muffler	Boîte d'échappement	Schalldämpfer
4	MKM50027AA	1	Tubo	Pipe, tail	Tuyau	Rohrleitung
5	MKM70026AA	1	Guarnizione	Gasket, muffler	Joint	Dichtscheibe
6	MKM01036AA004	2	Vite	Screw	Vis	Schraube
7	MN801A06	2	Dado	Nut, flange	Écrou	Mutter
8	MH071D05X012K	1	Vite	Screw	Vis	Schraube
9	MKU12018CA	1	Vite	Screw	Vis	Schraube
10	MKM21005AA	1	Coperchio marmitta	Cover, muffler	Couvercle	Schraube
11	MKU12018AA	1	Vite	Screw	Vis	Deckel Schraube

- 8 - FRIZIONE
- 8 - CLUTCH SYSTEM
- 8 - EMBRAYAGE
- 8 - KUPPLUNG

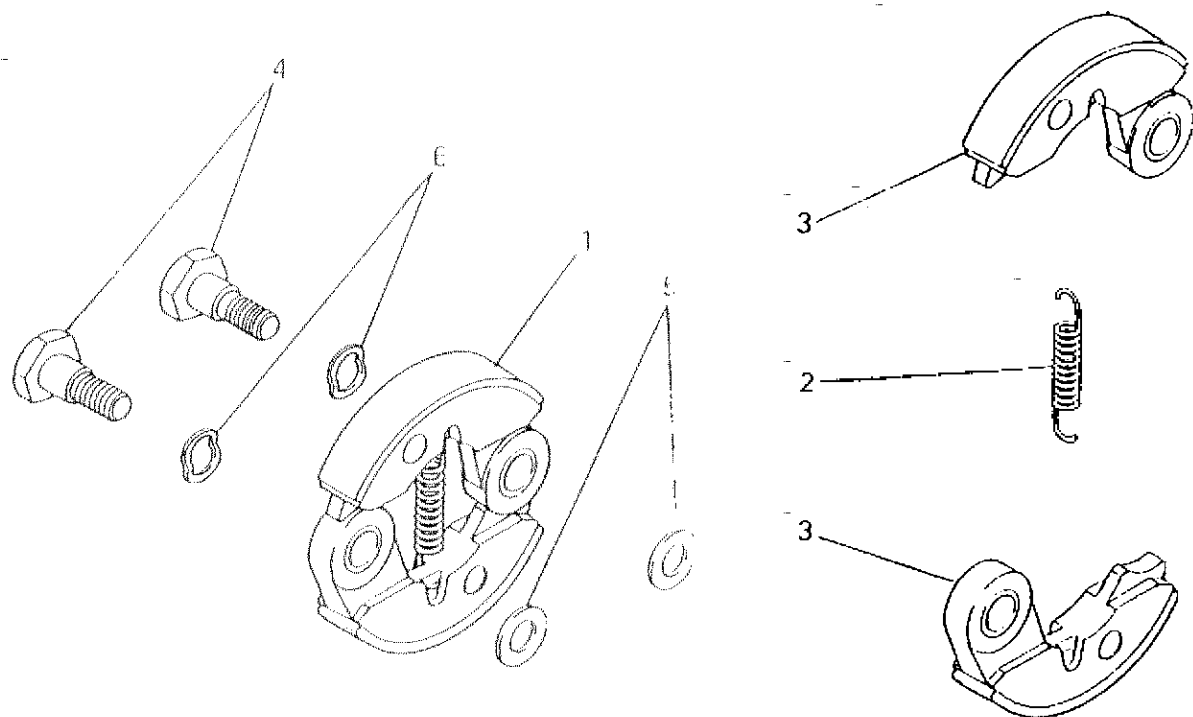

Nr.	Cod.	Q.ty	Descrizione	Description	Description	Beschreibung
1	MFR66843A	1	Frizione (incl. 2-3)	Clutch (incl. 2-3)	Embrayage (incl. 2-3)	Kupplung (incl. 2-3)
2	MKU80010AA	1	Molla	Spring	Ressort	Feder
3	MKT12002BA	2	Scarpa frizione	Shoe, clutch	Mâchoire d'embrayage	Kupplung
4	MKT14001AA	2	Bullone frizione	Bolt, clutch	Boulon	Schraube
5	MFR67347	2	Ranella	Washer	Rondelle	Unterlegscheibe
6	MKU36001AA	2	Ranella	Washer	Rondelle	Unterlegscheibe

- 9 - AVVIAMENTO
- 9 - RECOIL STARTER SYSTEM
- 9 - DÉMARREUR À MAIN
- 9 - ANLASSEN VON HAND

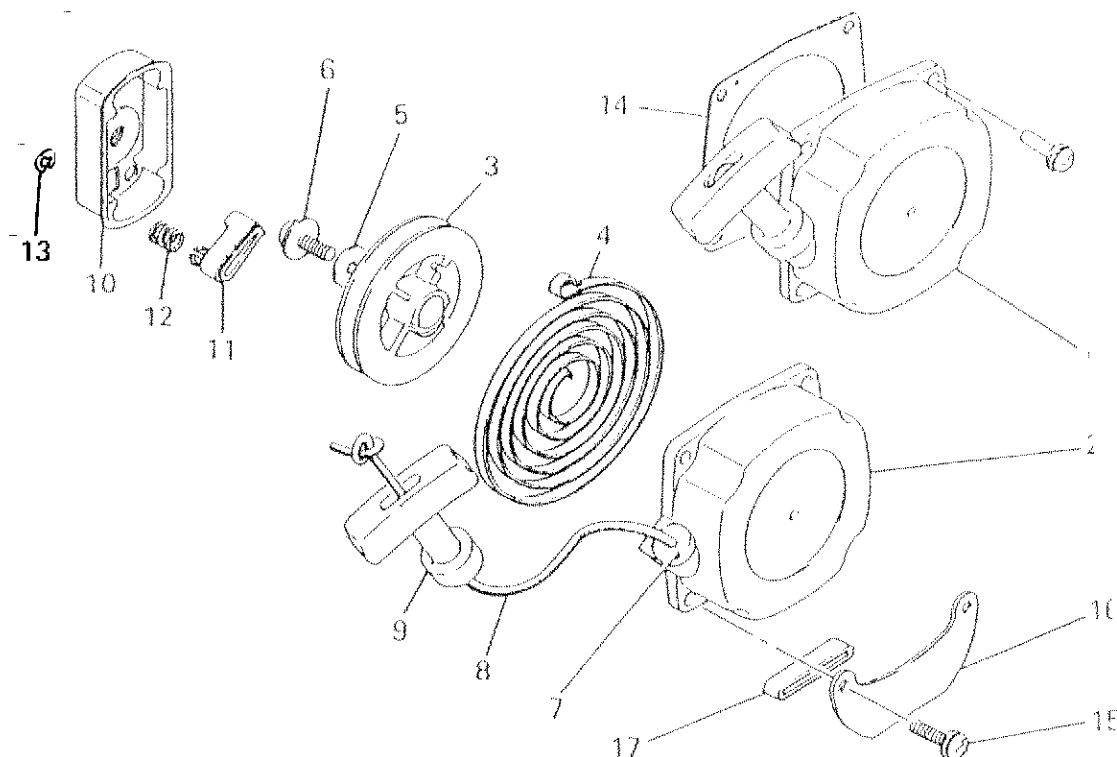

Nr.	Cod.	Q.ty	Descrizione	Description	Description	Beschreibung
	MKS02037AA	1	Avviamento (incl.2-9)	Recoil starter (incl.2-9)	Démarreur à main (incl.2-9)	Anlassen von Hand (incl.2-9)
2	MKS02037AA001	1	Carter avviamento	Case, starter	Boîtier	Gehäuse
3	MKS02037AA002	1	Puleggia	Reel	Poulie	Riemenscheibe
4	MKS02037AA003	1	Molla	Spring	Ressort	Feder
5	MKS02037AA004	1	Ranella	Washer	Rondelle	Unterlegscheibe
6	MKS02037AA005	1	Vite	Screw	Vis	Schraube
7	MKS20021AA006	1	Guida corda	Guide	Guide	Fuehrung
8	MKS02037AA008	1	Corda avviamento	Rope, starter	Corde	Schnur
9	MFR66881XX011	1	Manopola	Knob, Starter	Poignée	Griff
10	MKS03004BA	1	Innesto (incl.11-13)	Cover (incl.11-13)	Couvercle (incl.11-13)	Deckel (incl.11-13)
11	MKS03004AA002	1	Saltarello	Ratchet	Crochet	Sperrmocken
12	MKS03004BA103	1	Molla	Spring, return	Ressort	Feder
13	MKS03004AA004	1	Fermo	Snap ring	Collier	Halter
14	MKS90023AA	1	Piastra	Plate	Plaque	Platte
15	MKU12018CA	3	Vite	Screw	Vis	Schraube
16	MKF09017AA	1	Supporto (incl. 17)	Bracket (incl.17)	Support (incl. 17)	Halter (incl. 17)
17	MKF80004AA	1	Gommino	Pad	Épaisseur en cutchouc	Büchse

10 - SERBATOIO
 10 - FUEL TANK SYSTEM
 10 - RÉSERVOIR
 10 - TANK

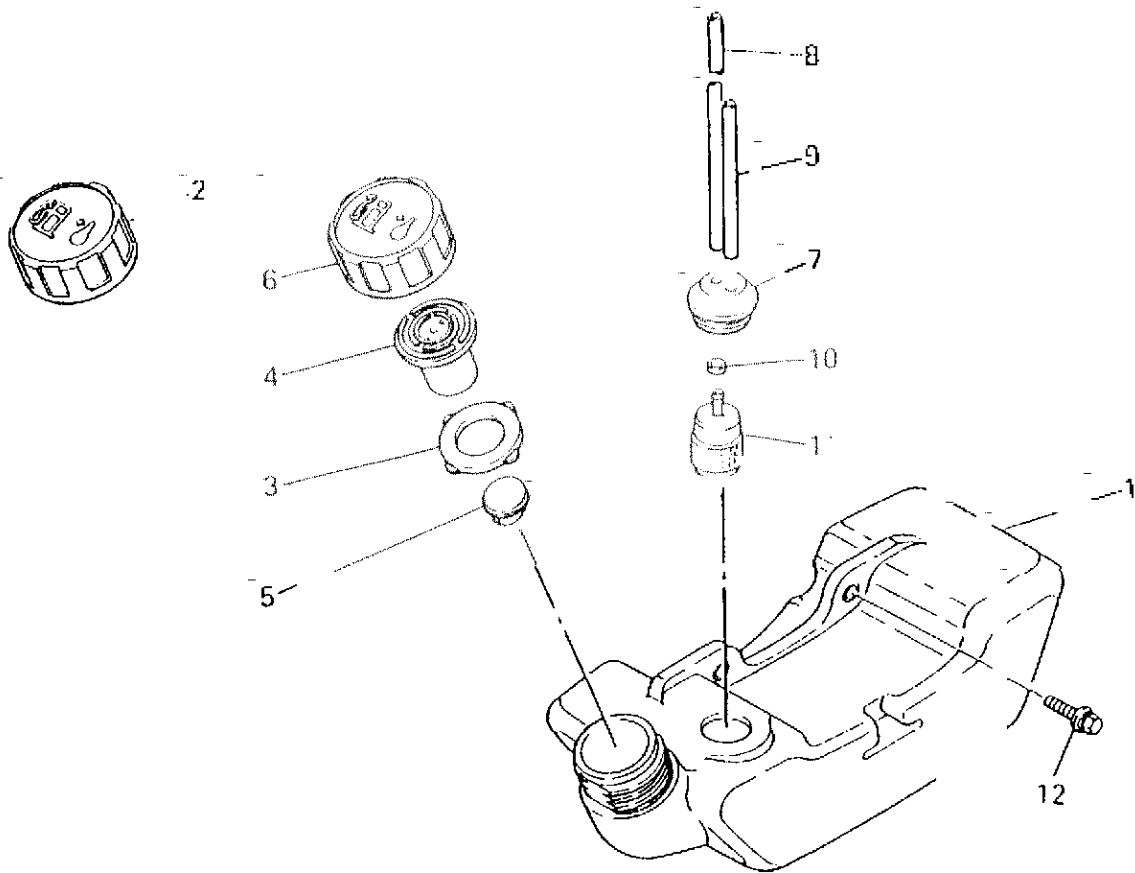

Nr.	Cod.	Q.ty	Descrizione	Description	Description	Beschreibung
1	MKF01058AA		Serbatoio (incl. 2-11)	Tank assy (incl. 2-11)	Réservoir (incl. 2-11)	Tank (incl. 2-11)
2	MKF05014AA		Tappo (incl. 3-6)	Cap assy (incl. 3-6)	Bouchon (incl. 3-6)	Tankverschluss (incl. 3-6)
3	MKF90049AA		Paraolio	Packing	Joint	Dichtscheibe
4	MKF09011AA		Valvola	Valve, breather	Soupape	Ventil
5	MKF90050AB		Tappo	Cap	Bouchon	Stopfen
6	MKF21012AA		Tappo serbatoio	Cap, fuel tank	Bouchon du réservoir	Tankverschluss
7	MKF90048AA		Tappo	Plug	Bouchon	Stopfen
8	MFR67142XX001		Tubo miscela	Tube, fuel	Tube	Brennstoffleitung
9	MFR64255B		Tubo miscela	Tube, fuel	Tube	Brennstoffleitung
10	MKF01033AA007		Bussola	Bushing	Bague	Buchse
11	MKF40004AA		Filtro carburante	Filter, fuel	Filtre carburant	Filter
12	MKU12016AA	2	Bullone	Bolt	Boulon	Schraube

- 11 - CARTER FRIZIONE
- 11 - CLUTCH CASE
- 11 - BOÎTIER D'EMBRAYAGE
- 11 - KUPPLUNG KASTEN

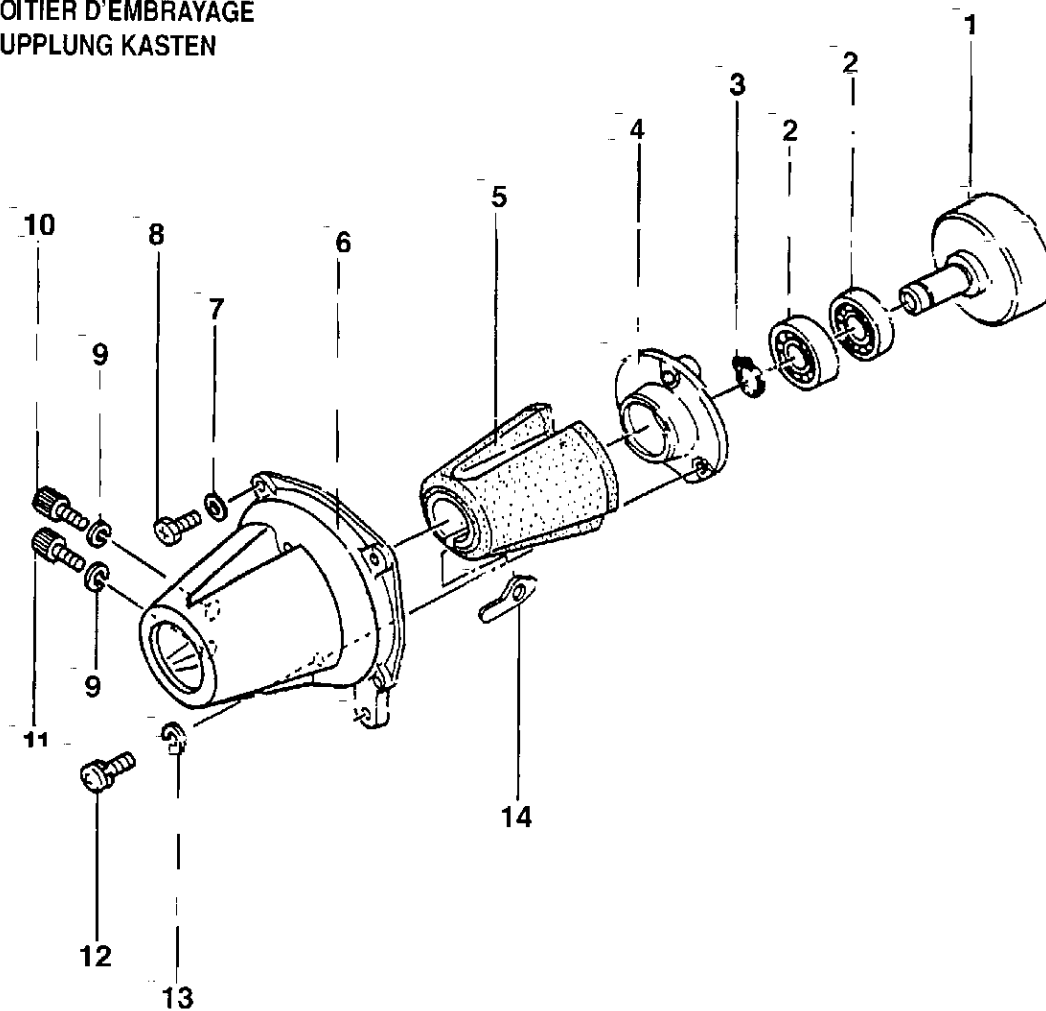

Nr.	Cod.	Q.ty	Descrizione	Description	Description	Beschreibung
1	P289-0143C-800B		Campana frizione	Clutch drum	Entraîneur	Trommel
2	P999-61600-102	2	Cuscinetto	Bearing	Roulement	Lager
3	1070001A1	1	Seeger	Stop ring	Seeger	Seeger
4	P374-0631A-20		Flangia	Flange	Flasque	Flansch
5	P599-0165A-80	1	Antivibrante	Cushion rubber	Amortiseur	Schwingungsdämpfer
6	P331-33684-20GR	1	Carter frizione	Clutch case	Boîtier d'embrayage	Kupplung kasten
7	1020008A1	4	Rondella	Washer	Rondelle	Unterlegscheibe
8	P1010261	4	Vite	Screw	Vis	Schraube
9	P1020056	2	Rondella	Washer	Rondelle	Unterlegscheibe
10	P990-51050-103		Vite	Screw	Vis	Schraube
11	P990-51050-203	1	Vite	Screw	Vis	Schraube
12	P1010207	3	Vite	Screw	Vis	Schraube
13	P1020056	3	Rondella	Washer	Rondelle	Unterlegscheibe
14	P249-0165A-21		Piastrina	Plate	Plaque	Platte

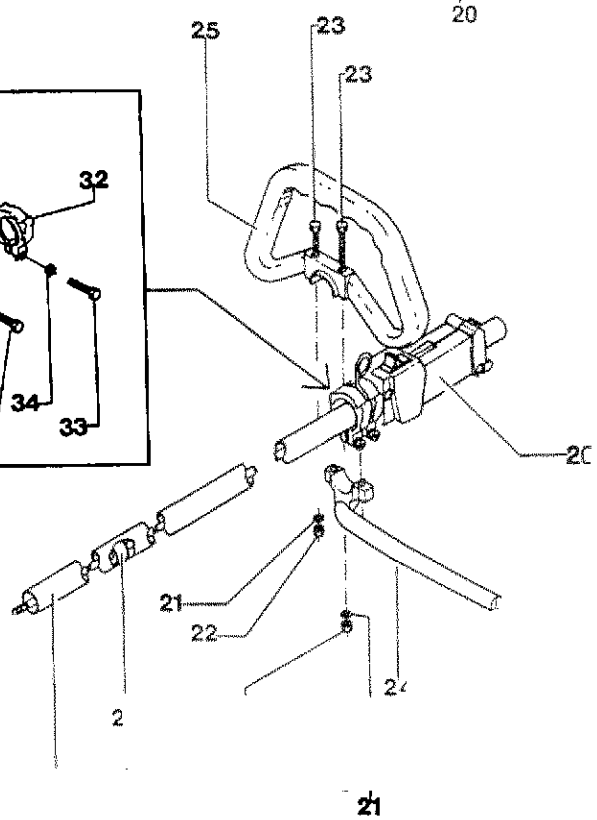
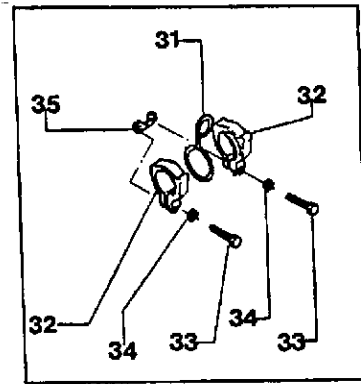
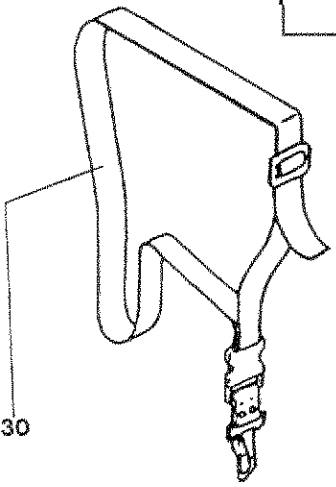
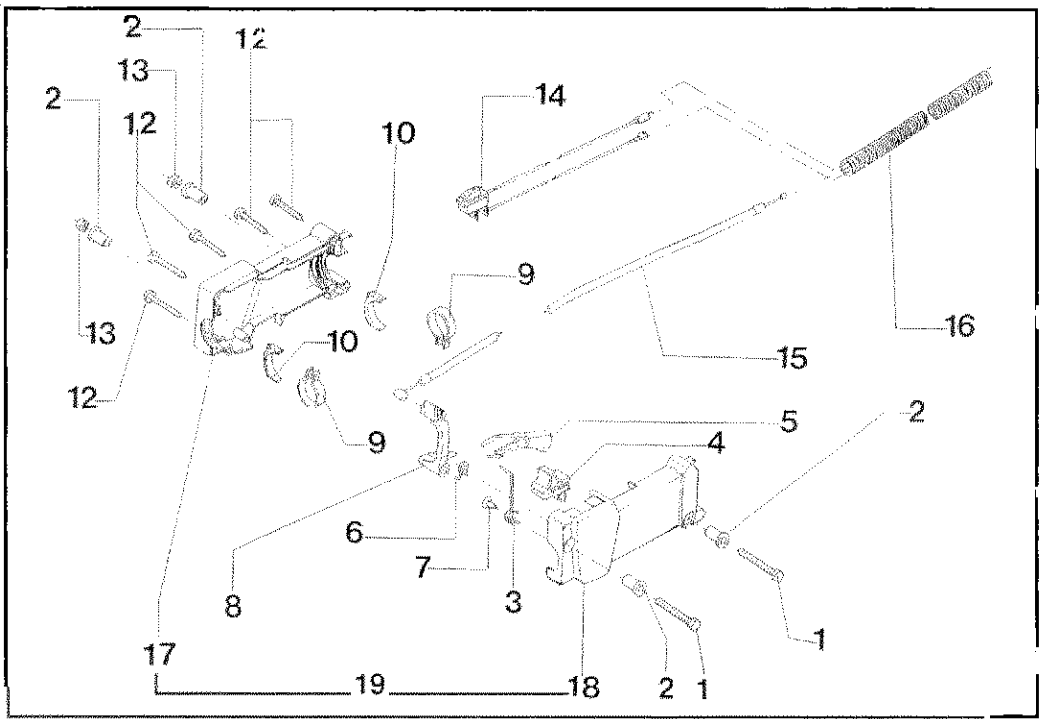

Nr.	Cod.	Q.ty	Descrizione	Description	Description	Beschreibung
1	1010002A1	2	Vite	Screw	Vis	Schraube
2	P3040320ZT	4	Bussola	Bushing	Douille	Buchse
3	P3020037ZT	1	Molla per pulsante	Spring	Ressort	Feder
4	P2020406R	1	Pulsante 1/2 gas	Half throttle button	Bouton de demi-gaz	Schlossdrucktaster
5	P2020388R	1	Leva di bloccaggio	Lever	Levier	Hebel
6	P3020036ZT	1	Molla	Spring	Ressort	Feder
7	P1020109	1	Ribattino	Rivet	Rivet	Niet
8	P2020409R	1	Leva acceleratore	Throttle lever	Levier de l'accélérateur	Gashebel
9	P4010243ZT	2	Fascetta	Clamp	Collier	Rapband
10	P2020385	4	Riduzione	Reduction	Réduction	Reduktion
12	P1010216	5	Vite	Screw	Vis	Schraube
13	1050002A1	2	Dado	Nut	Écrou	Mutter
14	P5080035	1	Interruttore completo	Switch assy	Interrupteur complet	Steuerung
15	P5020098	1	Cavo acceleratore	Throttle wire	Câble de l'accélérateur	Gaskabel
16	P164-10016-80	mt. 0,19	Guaina	Protection tube	Protection	Schutz
17			Vedi Nr 19	See Nr. 19	Voir Nr. 19	Siehe Nr. 19
18			Vedi Nr 19	See Nr. 19	Voir Nr. 19	Siehe Nr. 19
19	P2020417	1	Impugnatura	Handle	Portage	Steuerung
20	P3080043	1	Impugnatura compl.	Handle assy	Portage complet	Steuerung komp.
21	1020013A1	2	Rondella	Washer	Rondelle	Unterlegscheibe
22	1050003A1	2	Dado	Nut	Écrou	Mutter
23	P1010226	2	Vite	Screw	Vis	Schraube
24	P2020394	1	Asta di protezione	Protection shaft	Tige de protection	Stange
25	P500-35560-20	1	Manico asta	Single handle	Portage anneau	Griff
27	P343-33699-21	1	Albero trasmissione	Drive shaft	Arbre de transmission	Antriebswelle
28	P2020414	5	Gommino	Bushing	Douille	Büchse
29	P2090008	1	Asta con gommino	Drive shaft	Arbre de transmission	Antriebswelle
30	P746-33407-90	1	Bretelle	Harness	Bandoulière	Schultergurt
31	P335-37307-20	1	Supporto bretelle	Suspension hook	Support	Halterarm
32	P334-37352-21	2	Fermo supporto	Lifting metal collar	Collier de levage	Sperrung
33	P990-51050-303	2	Vite	Screw	Vis	Schraube
34	P992-01050-061	2	Rondella	Washer	Rondelle	Unterlegscheibe
35	P315-37304-20	1	Piastrina	Plate	Plaque	Platte

13 - ASTA CON IMPUGNATURA DOPPIA

13 - DOUBLE HANDLE

13 - ARBRE DE TRANSMISSION AVEC PORTAGE MANCHERONS

13 - ANTRIEBSWELLE + DOPPELGRIF

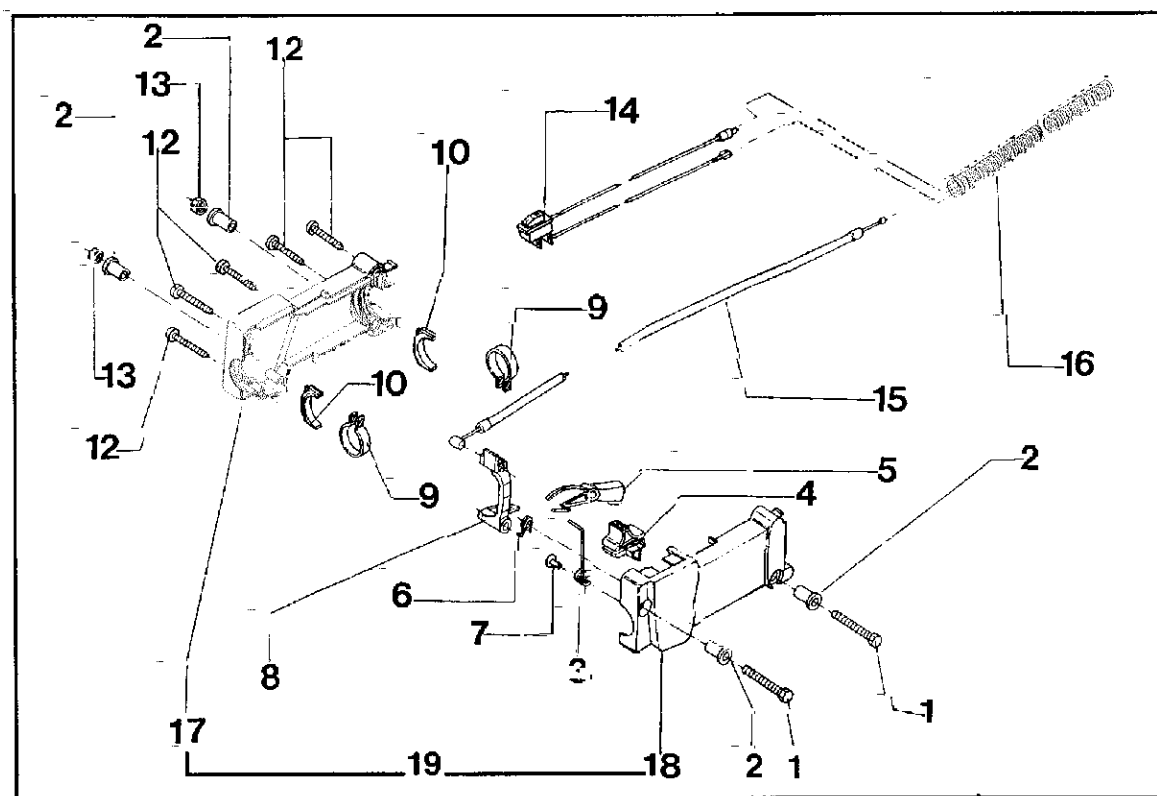

20

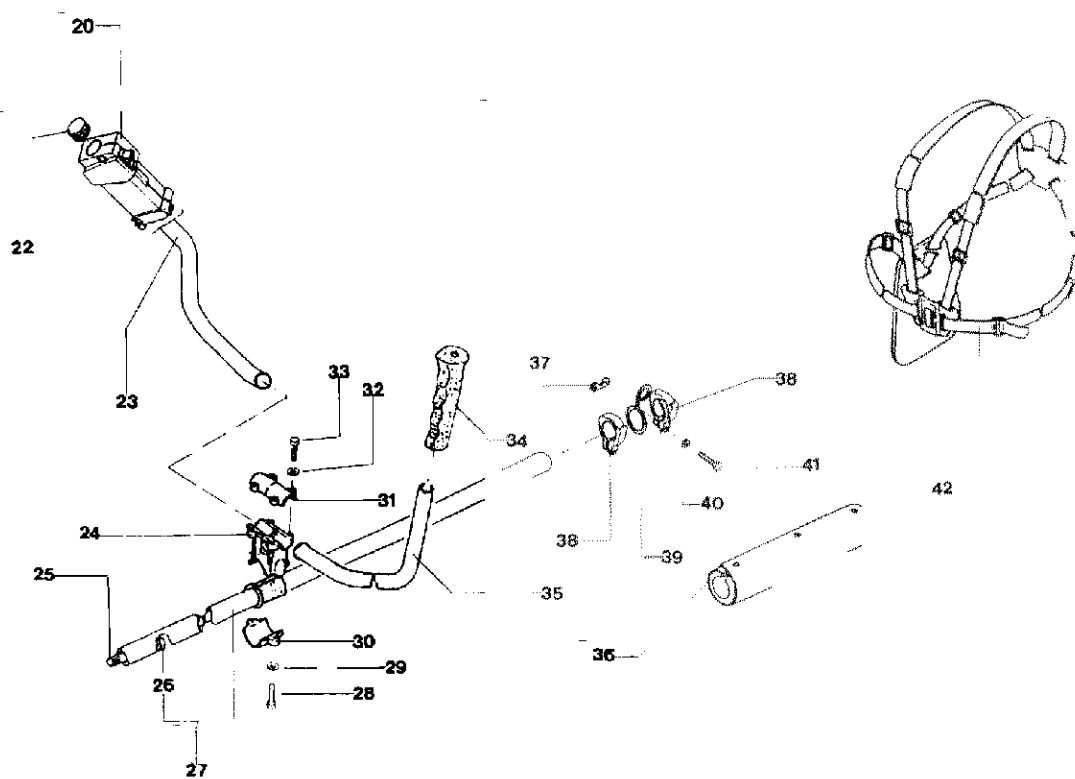

Nr.	Cod.	Q.ty	Descrizione	Description	Description	Beschreibung
1	1010002A1	2	Vite	Screw	Vis	Schraube
2	P3040320ZT	4	Bussola	Bushing	Douille	Buchse
3	P3020037ZT	1	Molla per pulsante	Spring	Ressort	Feder
4	P2020406R	1	Pulsante 1/2 gas	Half throttle button	Bouton de demi-gaz	Schlossdrucktaster
5	P2020388R	1	Leva di bloccaggio	Lever	Levier	Hebel
6	P3020036ZT	1	Molla	Spring	Ressort	Feder
7	P1020109	1	Ribattino	Rivet	Rivet	Niet
8	P2020409R	1	Leva acceleratore	Throttle lever	Levier de l'accélérateur	Hashebel
9	P4010244ZT	2	Fascetta	Clamp	Collier	Rapband
10	P2020384	4	Riduzione	Reduction	Réduction	Reduktion
12	P1010216	5	Vite	Screw	Vis	Schraube
13	1050002A1	2	Dado	Nut	Écrou	Mutter
14	P5080036	1	Interruttore completo	Switch assy	Interrupteur complet	Steuerung
15	P5020084	1	Cavo acceleratore	Throttle wire	Câble de l'accélérateur	Gaskabel
16	P164-10016-80	mt. 0,70	Guaina	Protection tube	Protection	Schutz
17			Vedi Nr 19	See Nr. 19	Voir Nr. 19	Siehe Nr. 19
18			Vedi Nr 19	See Nr. 19	Voir Nr. 19	Siehe Nr. 19
19	P2020417	1	Impugnatura	Double handle	Portage	Steuerung
20	P3080041	1	Impugnatura compl.	Double handle assy	Portage complet	Steuerung komp.
22	P5060012	1	Tappo	Plug	Bouchon	Stopfen
23	P3120119ZT	1	Tubo dx	Tube, r.h.	Tuyau droit	Rhorleitung r.
24	P507-37623-20GR	1	Supporto manico	Handle holder	Support du portage	Halter
25	P343-33699-21	1	Albero trasmissione	Drive shaft	Arbre de transmission	Antriebswelle
26	P2090014	5	Gommino	Bushing	Douille	Büchse
27	P2090008	1	Asta con gommino	Drive shaft	Arbre de transmission	Antriebswelle
28	P990-53060-253	2	Vite	Screw	Vis	Schraube
29	1020008A1	2	Rondella	Washer	Rondelle	Unterlegscheibe
30	P508-37623-20GR	1	Supporto manico inf.	Handle holder, lower	Support inf.	Halter
31	P506-37623-20GR	1	Supporto manico sup.	Handle holder, upper	Support sup.	Halter
32	P1020056	4	Rondella	Washer	Rondelle	Unterlegscheibe
33	P990-51050-303	4	Vite	Screw	Vis	Schraube
34	P165-33130-20	1	Manopola	Handle	Poignée	Griff
35	P502-33674-20	1	Tubo sx	Tube, l.h.	Tuyau gauche	Rhorleitung l.
36	P336-33411-82	1	Protezione cavi	Cable protection	Protection	Protektion
37	P315-37304-20	1	Piastrina	Plate	Plaque	Platte
38	P334-37352-21	2	Fermo supporto	Lifting metal collar	Collier de levage	Sperrung
39	P335-37307-20	1	Supporto bretella	Suspension hook	Métal de levage	Halterarm
40	P992-01050-061	2	Rondella	Washer	Rondelle	Unterlegscheibe
41	P990-51050-303	2	Vite	Screw	Vis	Schraube
42	P746-37455-90	1	Bretella	Harness	Bandoulière	Schultergurt

MBC 430 K

- 14 - ZAINO PORTA MOTORE
- 14 - KNAP SACK
- 14 - PORTAGE DORSAL
- 14 - RUCKSACK

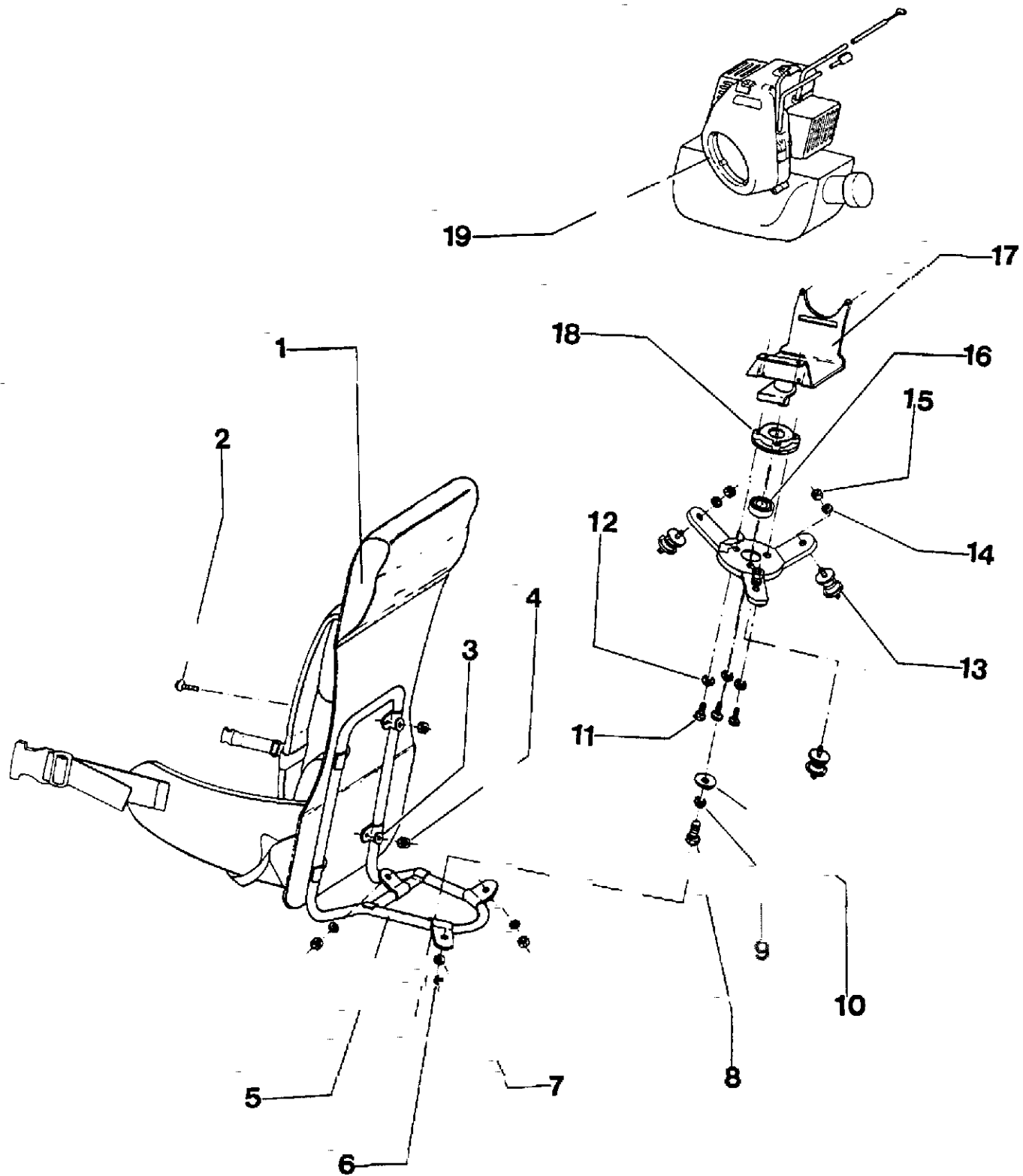

Nr.	Cod.	Q.ty	Descrizione	Description	Description	Beschreibung
1	P4040002	1	Zaino	Knap sack	Portage dorsal	Rucksack
2	P1010238	4	Vite	Screw	Vis	Schraube
3	P1020055	4	Rondella	Washer	Rondelle	Unterlegscheibe
4	P1010237	4	Dado	Nut	Écrou	Mutter
5	P3060089VE	1	Telaio	Frame	Châssis	Rahmen
6	P1050007	3	Dado	Nut	Écrou	Mutter
7	1020008A1	3	Rondella	Washer	Rondelle	Unterlegscheibe
8	P1010119	1	Vite	Screw	Vis	Schraube
9	P1020117	1	Rondella elastica	Washer	Rondelle	Unterlegscheibe
10	P1020125	1	Rondella	Washer	Rondelle	Unterlegscheibe
11	P1010066	3	Vite	Screw	Vis	Schraube
12	1020008A1	3	Rondella	Washer	Rondelle	Unterlegscheibe
13	P319-33390-80	3	Antivibrante	Vibration damping	Antivibratoire	Schwingungsdämpfer
14	1020008A1	3	Rondella	Washer	Rondelle	Unterlegscheibe
15	P1050007	3	Dado	Nut	Écrou	Mutter
16	P999-61600-201	1	Cuscinetto	Bearing	Roulement	Lager
17	P3060120ZT	1	Piastra porta motore	Engine support plate	Plaque support moteur	Platte
18	P602-33411-201	1	Flangia	Flange	Flasque	Flansch
19		1	Motore	Engine	Moteur	Motor
20	P4010362ZT	1	Supporto motore	Engine support	Support du moteur	Halter

CRL PPO FLESSI
EXIB. I. H. FT
RA MISSON FL IBLE
GSAMI WELLE

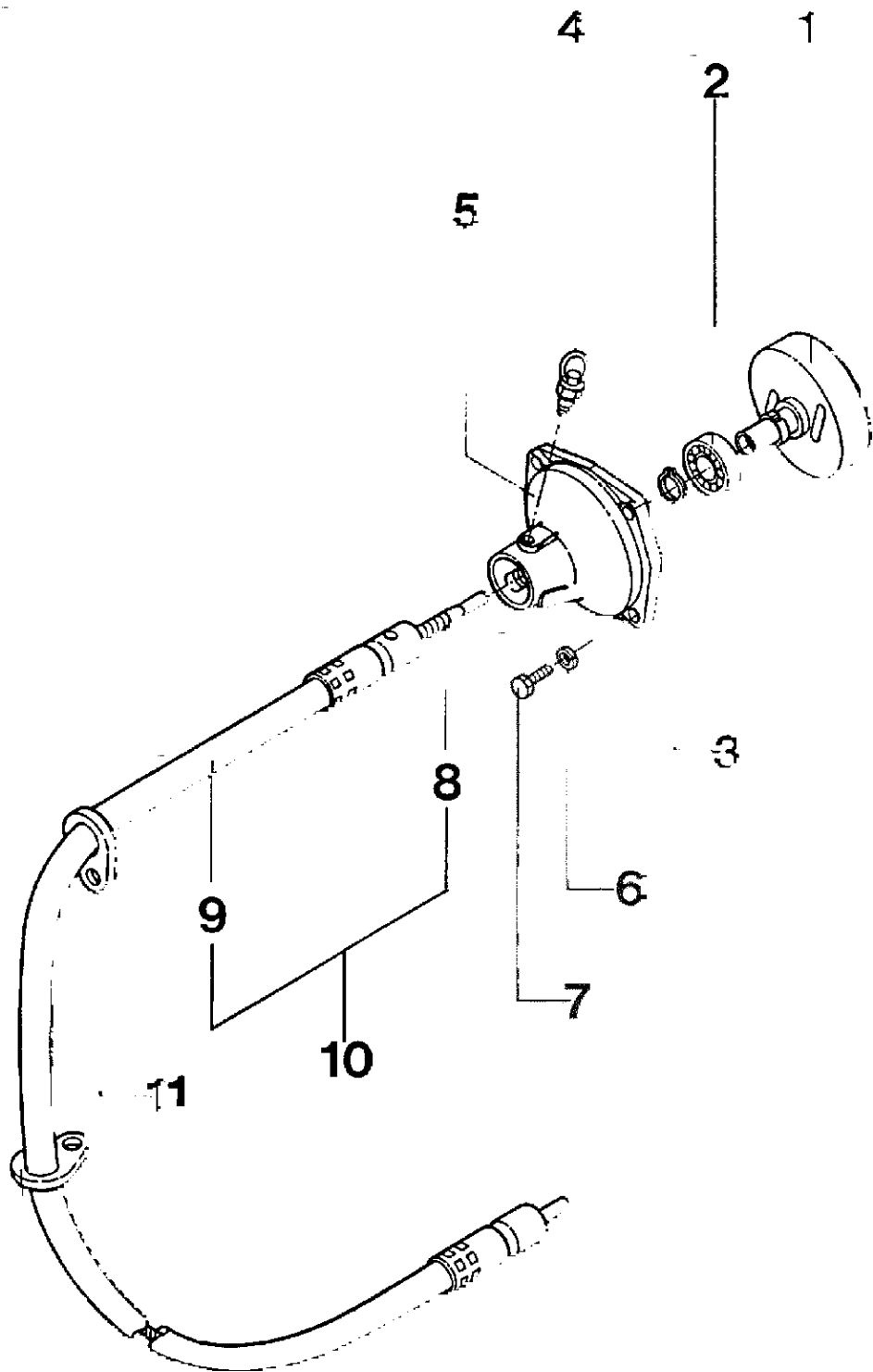

Nr.	Cod.	Q.ty	Descrizione	Description	Description	Beschreibung
1	P3060075BR	1	Campana frizione	Clutch drum	Entraîneur	Trommel
2	P999-61620-201	1	Cuscinetto	Bearing	Roulement	Lager
3	P993-50015-002	1	Seeger	Stop ring	Seeger	Seeger
4	P400-33365-80	1	Gancio fissaggio	Hook	Métal de levage	Haken
5	P331-33380-20GR	1	Carter frizione	Clutch case	Boîtier	Kupplung kasten
6	1020008A1	4	Rondella	Washer	Rondelle	Unterlegscheibe
7	P1010261	4	Vite	Screw	Vis	Schraube
8	P351-3338F-800	1	Flessibile interno	Transmission shaft	Arbre de transmission	Biegsame Welle
9	P350-33390-801	1	Flessibile esterno	Flexible pipe	Tuyau flexible	Schutzhülle
10	P351-3338F-900	1	Flessibile completo	Transmission shaft assy	Arbre de transmission comp.	Biegsame Welle
11	P198-33386-20	2	Gommino	Pad	Épaisseur en cutchouc	Hülse

MBC 430 K

ASTA DOI IMPLUGI ATJR.
LAFT WITH IGI IANI
AFBRI DE TRA ISMI SIDI EC PORTAG
ANTI IE ISWEI FACH3RIFF

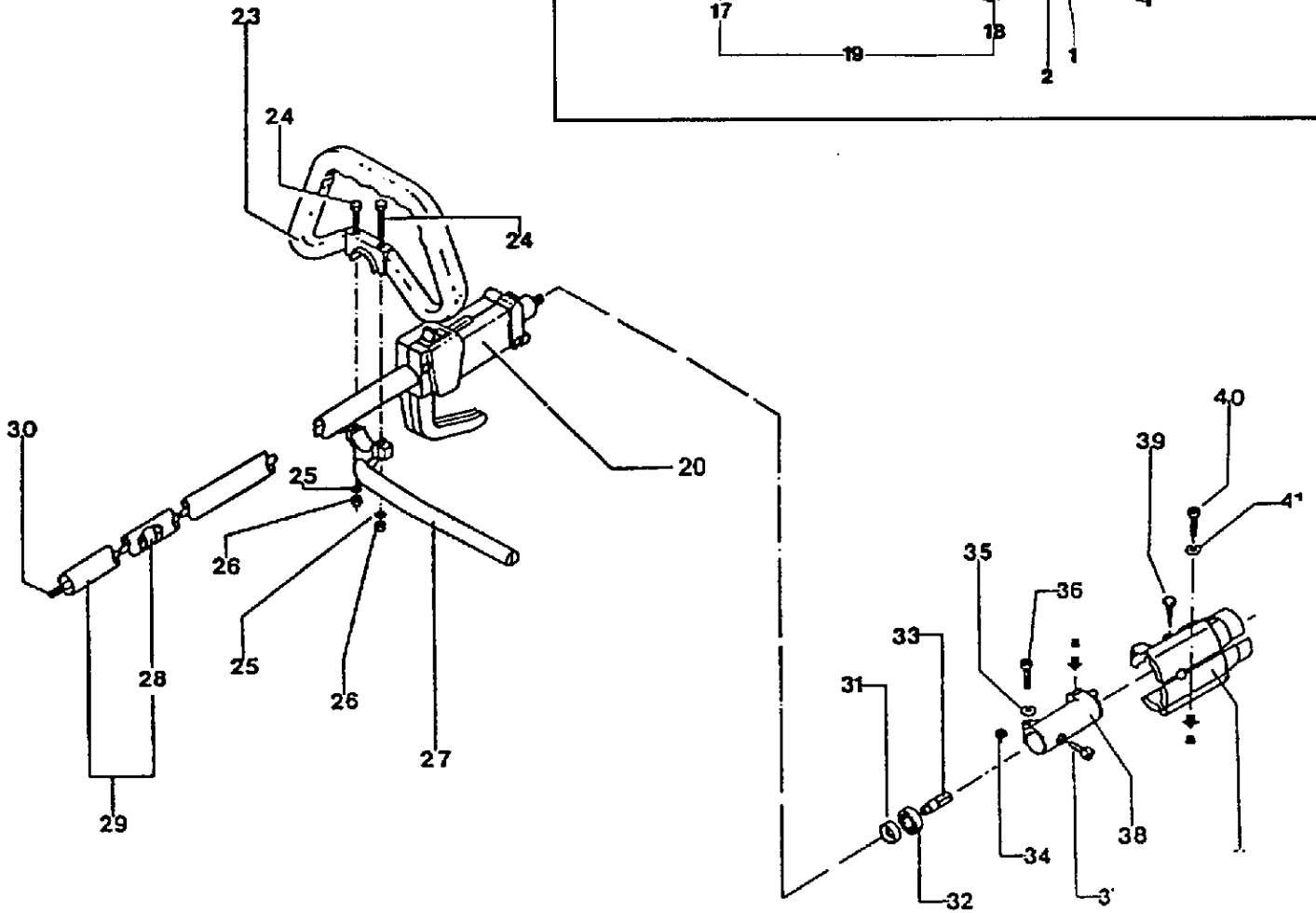
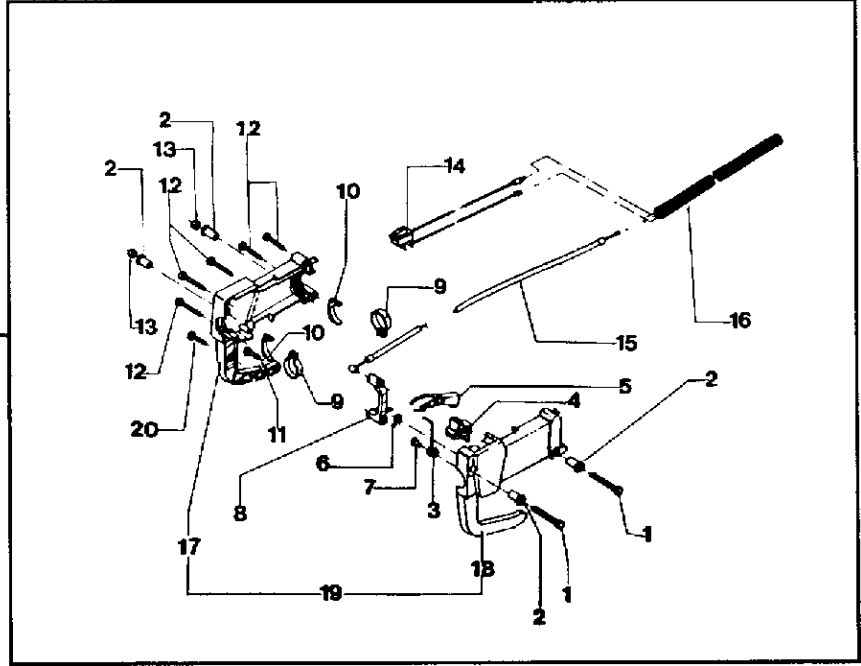

Nr.	Cod.	Q.ty	Descrizione	Description	Description	Beschreibung
1	1010002A1	2	Vite	Screw	Vis	Schraube
2	P3040320ZT	4	Bussola	Bushing	Douille	Buchse
3	P3020037ZT	1	Molla per puisante	Spring	Ressort	Feder
4	P2020406R	1	Puisante 1/2 gas	Half throttle button	Bouton de demi-gaz	Schlossdrucktaster
5	P2020388R	1	Leva di bloccaggio	Lever	Levier	Hebel
6	P3020036ZT	1	Molla	Spring	Ressort	Feder
7	P1020109	1	Ribattino	Rivet	Rivet	Niet
8	P2020409R	1	Leva acceleratore	Throttle lever	Levier de l'accélérateur	Gashebel
9	P4010244ZT	2	Fascetta	Clamp	Collier	Rapband
10	P2020384	4	Riduzione	Reduction	Réduction	Reduktion
12	P1010216	5	Vite	Screw	Vis	Schraube
13	1050002A1	2	Dado	Nut	Écrou	Mutter
14	P5080037	1	Interruttore completo	Switch assy	Interrupteur complet	Steuerung
15	P5020090	1	Cavo acceleratore	Throttle wire	Câble de l'accélérateur	Gaskabel
16	P164-10016-80	mt. 0,75	Guaina	Protection tube	Protection	Schutz
17			Vedi Nr. 19	See Nr. 19	Voir Nr. 19	Siehe Nr. 19
18			Vedi Nr. 19	See Nr. 19	Voir Nr. 19	Siehe Nr. 19
19	P2020413	1	Impugnatura	Handle	Poignée	Steuerung
20	P3080044	1	Impugnatura completa	Handle assy	Poignée complète	Steuerung komp.
23	P500-33560-20	1	Manico asta	Single handle	Portage anneau	Griff
24	P1010226	2	Vite	Screw	Vis	Schraube
25	1020013A1	2	Rondella	Washer	Rondelle	Unterlegscheibe
26	1050003A1	2	Dado	Nut	Écrou	Mutter
27	P2020394	1	Asta di protezione	Protection shaft	Tige de protection	Stange
28	P2090014	4	Gommino	Bushing	Douille	Büchse
29	P2090009	1	Asta con gommini	Drive shaft	Arbre de transmission	Antriebswelle
30	P3040385	1	Albero di trasmissione	Drive shaft	Arbre de transmission	Antriebswelle
31	P342-33328-20	1	Rondella	Washer	Rondelle	Unterlegscheibe
32	P999-61600-004	1	Cuscinetto	Bearing	Roulement	Lager
33	P356-33386-20	1	Adattatore	Adapter	Adaptateur	Passtück
34	P992-01050-061	1	Rondella	Washer	Rondelle	Unterlegscheibe
35	P1020056	1	Rondella	Washer	Rondelle	Unterlegscheibe
36	P990-51050-253	1	Vite	Screw	Vis	Schraube
37	P990-51050-103	1	Vite	Screw	Vis	Schraube
38	P281-33386-21	1	Supporto	Holder	Support	Halter
39	P1010179	1	Vite	Screw	Vis	Schraube
40	P990-51050-203	1	Vite	Screw	Vis	Schraube
41	P1020056	1	Rondella	Washer	Rondelle	Unterlegscheibe
42	P285-33386-20	1	Protezione supporto	Protection	Protection	Protektion

- 17 - COPPIA CONICA
- 17 - GEAR CASE
- 17 - CARTER D'ENGRENAGE
- 17 - KEGELRADERPAARUNG

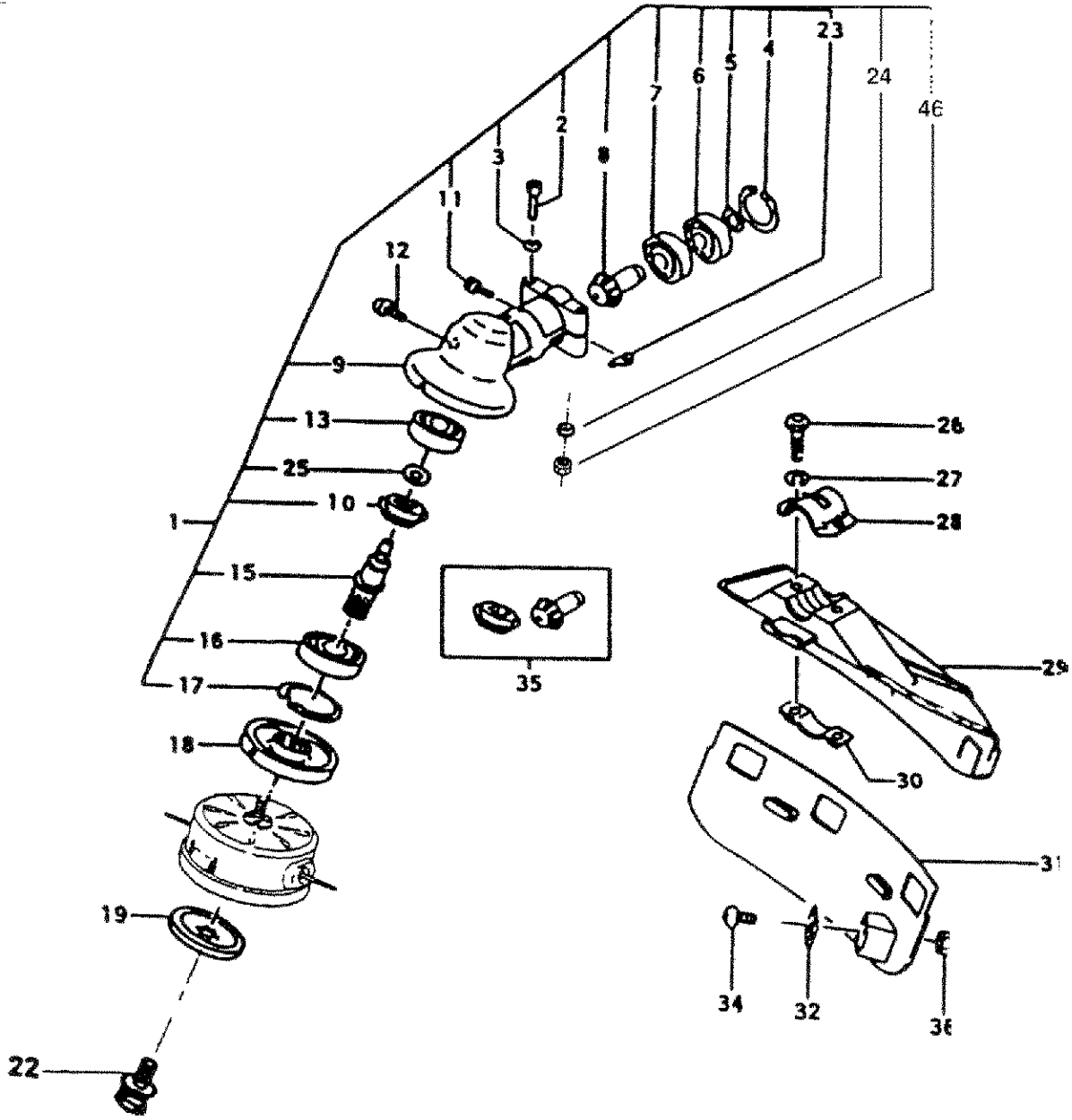

Nr.	Cod.	Q.ty	Descrizione	Description	Description	Beschreibung
	P300-37134-90		Scatola completa	Gear case assy	Carter d'engrenage comp.	Kegeltrieb komp.
2	P1010235	2	Vite	Screw	Vis	Schraube
3	P1020056	2	Rondella	Washer	Rondelle	Unterlegscheibe
4	P993-51024-002		Seeger	Stop ring	Seeger	Seeger
5	P993-50009-002		Seeger	Stop ring	Seeger	Seeger
6	P999-61609-002		Cuscinetto	Bearing	Roulement	Lager
7	P999-61609-000		Cuscinetto	Bearing	Roulement	Lager
8			Vedi Nr. 35	See Nr. 35	Voir Nr. 35	Siehe Nr. 35
9	P300-3330B-20GR		Carter testina	Gear case	Carter d'engrenage	Kasten
10			Vedi Nr. 35	See Nr. 35	Voir Nr. 35	Siehe Nr. 35
11	P990-51050-103	1	Vite	Screw	Vis	Schraube
12	P990-15080-100	1	Vite	Screw	Vis	Schraube
13	P999-61628-000	1	Cuscinetto	Bearing	Roulement	Lager
15	P304-37134-200	1	Alberino	Shaft	Arbre	Welle
16	P999-61620-103	1	Cuscinetto	Bearing	Roulement	Lager
17	P1070013	1	Seeger	Stop ring	Seeger	Seeger
18	P310-37623-20	1	Supporto sup. lama	Cutter holder, upper	Support de lame sup.	Halter
19	P311-37300-20	1	Supporto inf. lama	Cutter holder, lower	Support de lame inf.	Halter
22	P312-33386-20	1	Vite	Screw	Vis	Schraube
23	P992-01050-061	1	Rondella	Washer	Rondelle	Unterlegscheibe
24	P1020055	2	Rondella	Washer	Rondelle	Unterlegscheibe
25	P067-37134-20		Rondella	Washer	Rondelle	Unterlegscheibe
26	P1010261	2	Vite	Screw	Vis	Schraube
27	1020008A1	2	Rondella	Washer	Rondelle	Unterlegscheibe
28	P442-37380-20		Supporto superiore	Bracket, upper	Support sup.	Lager
29	P2020403NE		Protezione superiore	Safety guard, upper	Couvercle de securité sup.	Schutz
30	P445-37380-20		Supporto inferiore	Bracket, lower	Support inf.	Lager
31	P2020404NE		Protezione inferiore	Safety guard, lower	Couvercle de securité inf.	Schutz
32	P4010353BR		Coltello taglia filo	Wire cutter	Lame de coupage fil	Schneide
34	P994-14050-121		Vite	Screw	Vis	Schraube
35	P2090011		Coppia conica	Gear assy	Couple conique	Kegelraderpaarung
36	1050002A1		Dado	Nut	Écrou	Mutter
46	1050002A1	2	Dado	Nut	Écrou	Mutter

- 1 - GRUPPO CASSA
- 1 - CRANKCASE SYSTEM
- 1 - BOÎTIER
- 1 - GEHÄUSE

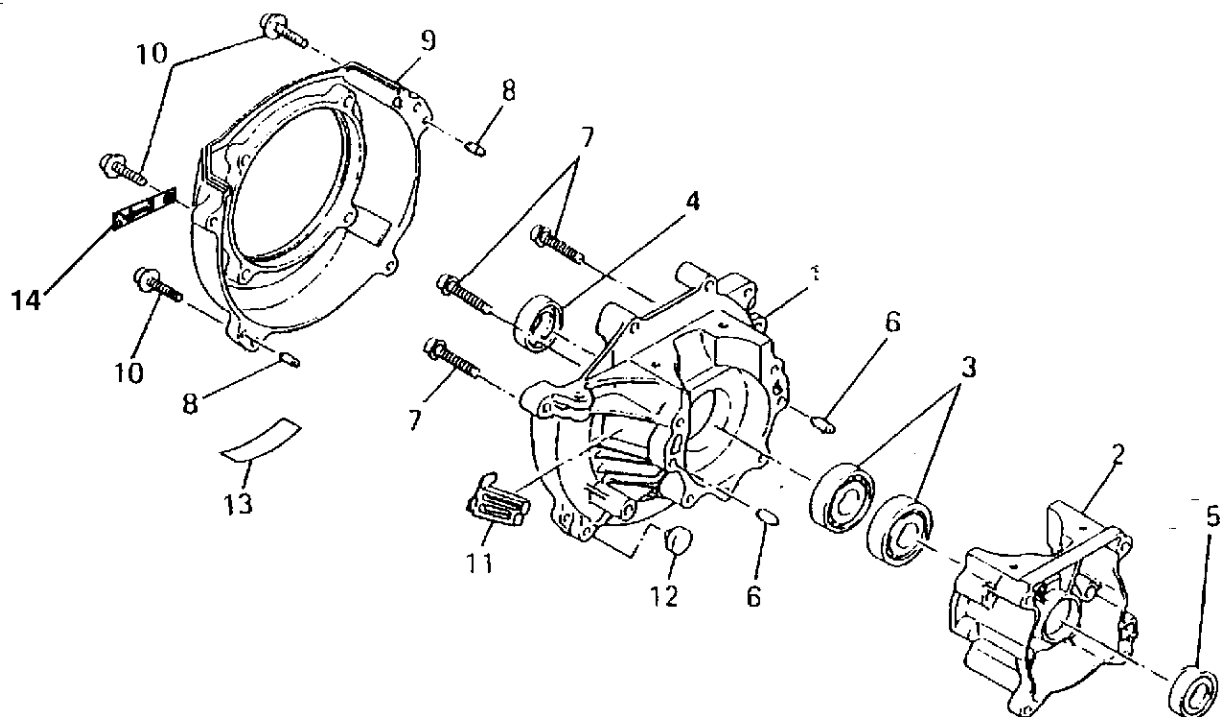

Nr.	Cod.	Q.ty	Descrizione	Description	Description	Beschreibung
1	MKB15001AA	1	Carter motore	Case, drive	Boîtier	Gehäuse
2	MKB15002AA	1	Cassa motore	Case, starter	Boîtier	Gehäuse
3	MS111X62X020	2	Cuscinetto a sfera	Bearing, ball	Roulement	Lager
4	MFR66462	1	Paraolio	Seal oil	Joint torique	Dichtring
5	MKW21005AA	1	Paraolio	Seal oil	Joint torique	Dichtring
6	MKU40003AA	2	Spina	Pin, dowel	Goupille	Bolzen
7	MH081D05X030	4	Vite	Screw	Vis	Schraube
8	MKU40004AA	2	Spina	Pin, dowel	Goupille	Bolzen
9	MKH30016AA	1	Protezione	Protection	Protection	Schutz
10	MFR64569D	4	Bullone	Bolt	Boulon	Schraube
11	MKH90024AA	1	Coperchio	Cover	Couvercle	Deckel
12	MKF80005AA	2	Gommino	Pad	Épaisseur en caoutchouc	Distanzbüchse
13	MKW56056AA	1	Decalcomania	Decal	Autocollant	Abziehbild
14	MKU60001AA	1	Fermo	Clamp	Collier	Klammer