

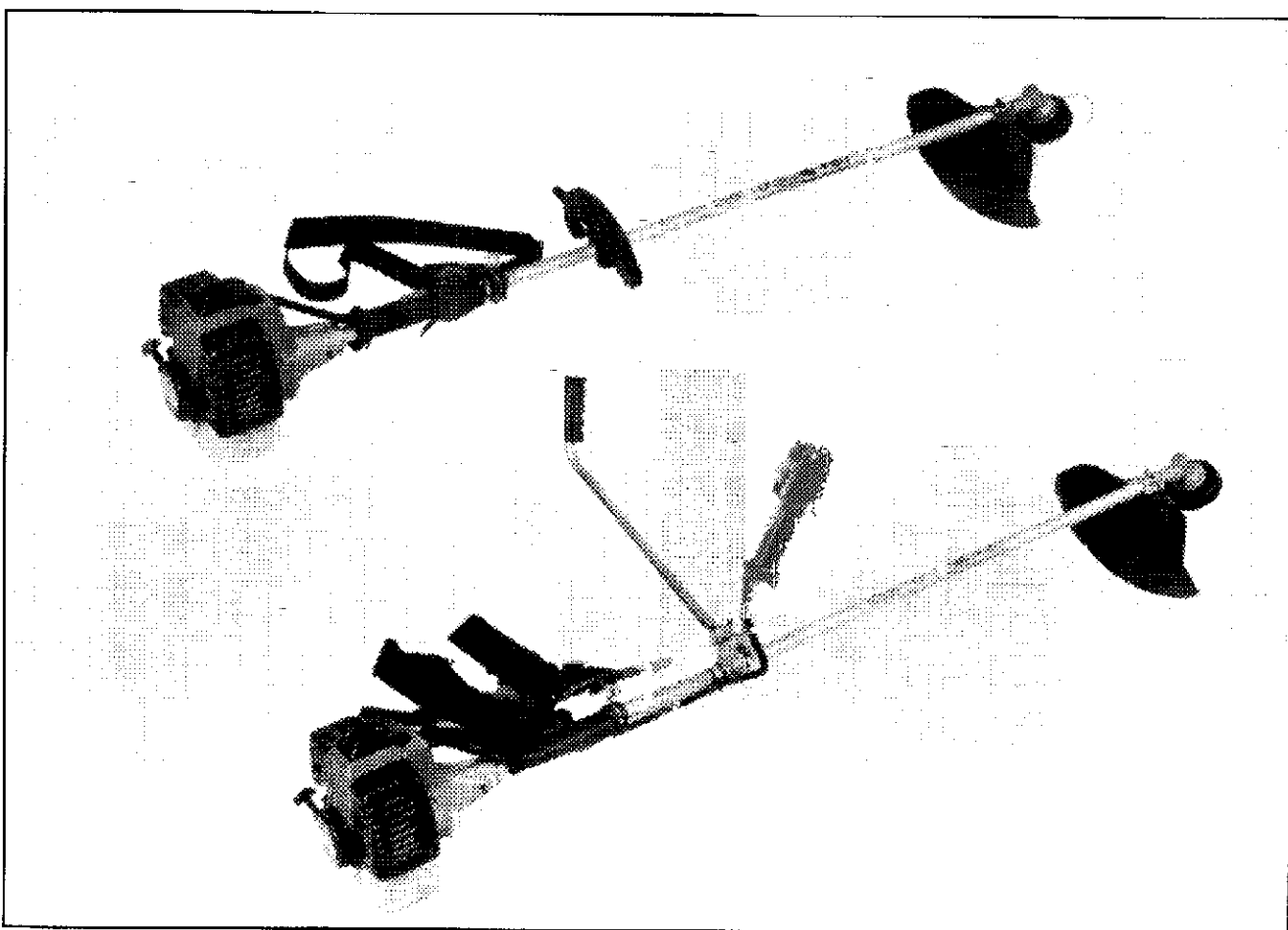

Stampato nr. / Form no.  
Imprimé no. / Drucksachen Nr.  
P5090271

**LISTA RICAMBI  
SPARE PARTS LIST  
LISTE DES PIÈCES DE RECHANGE  
ERSATZTEILLISTE**



**DECESPUGLIATORE  
BRUSH CUTTER  
DÉBROUSSAILLEUSE  
FREISCHNEIDER**

***MBC 350/350 D***

- 15 - DECALCOMANIA E ATTREZZI
- 15 - DECALS AND TOOLS
- 15 - AUTOCOLLANTS ET OUTILLAGE
- 15 - ABZIEHBILD

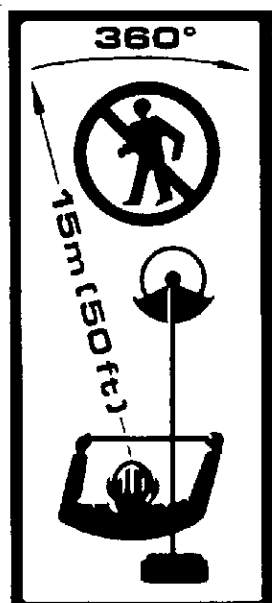

1



2

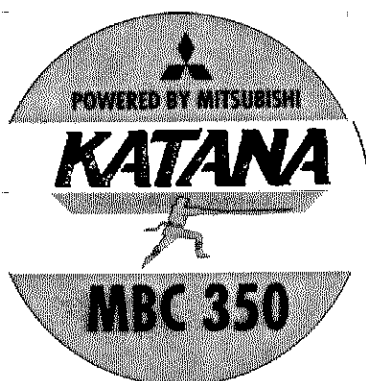

3

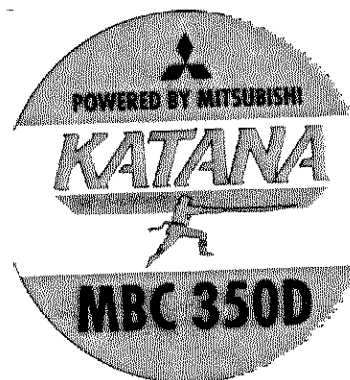

4

Nr.	Cod.	Q.ty	Descrizione	Description	Description	Beschreibung
1	P920-37504-200	1	Decalcomania	Decal	Autocollant	Abziehbild
2	P5140708	1	Decalcomania	Decal	Autocollant	Abziehbild
3	P5140703	1	Decalcomania	Decal	Autocollant	Abziehbild
4	P5140704	1	Decalcomania	Decal	Autocollant	Abziehbild
	P5110018	1	Chiave a brugola 4	Allen wrench 4	Clé 4	Schlüssel 4
	P5110019	1	Chiave fissa 8/10	Allen wrench 8/10	Clé 8/10	Schlüssel 8/10
	P5110020	1	Chiave 17/19	Spanner 17/19	Clé 17/19	Schlüssel 17/19

2 - CILINDRO  
 2 - CYLINDER  
 2 - CYLINDRE  
 2 - ZYLINDER

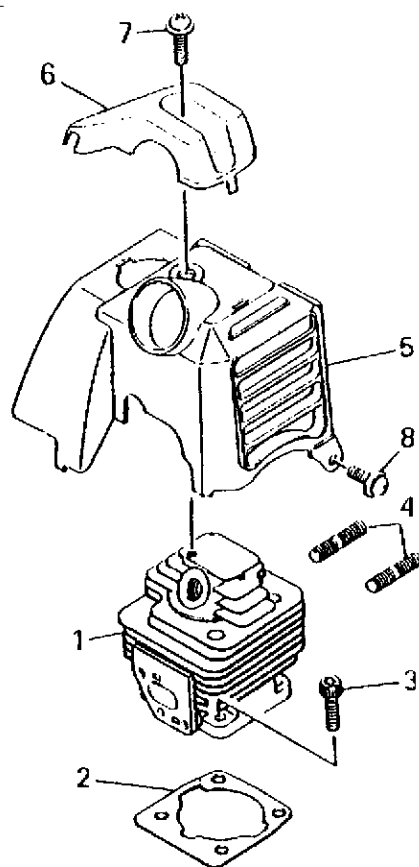

Nr.	Cod.	Q.ty	Descrizione	Description	Description	Beschreibung
1	MKC13011AA	1	Cilindro	Cylinder	Cylindre	Zylinder
2	MKW32003BA	1	Guarnizione cilindro	Gasket, cylinder	Joint	Dichtscheibe
3	MB121C05X016	4	Bullone	Bolt	Boulon	Schraube
4	MB151B05X050	2	Prigioniero	Bolt, stud	Goujon	Stehbolzen
5	MKH40031BA	1	Coperchio cilindro	Cover, cylinder	Couvercle	Deckel
6	MKH70008AA	1	Protezione	Guard, plug	Protection	Schutz
7	MH071D05X020K	1	Vite	Screw	Vis	Schraube
8	MKU12018CA	1	Vite	Screw	Vis	Schraube

- 3 - ALBERO MOTORE E PISTONE
- 3 - CRANKSHAFT & PISTON SYSTEM
- 3 - ARBRE MOTEUR ET PISTON
- 3 - KURBELWELLE

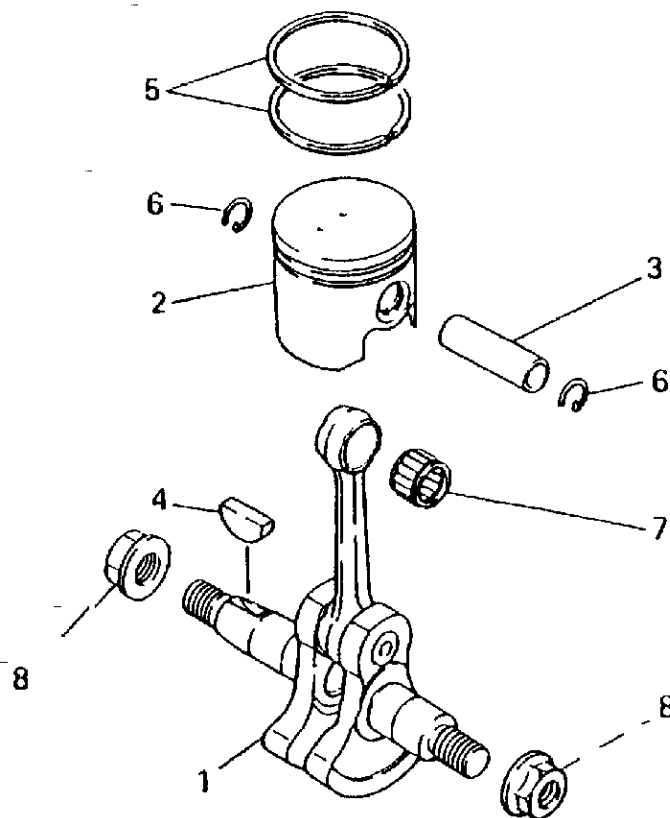

Nr.	Cod.	Q.ty	Descrizione	Description	Description	Beschreibung
1	MKD01022DA	1	Albero motore	Crankshaft	Arbre moteur	Kurbelwelle
2	MKP01031AA	1	Pistone (incl. 3)	Piston set (incl. 3)	Piston (incl.3)	Kolben (incl. 3)
3	MFR66814	1	Spinotto	Pin, piston	Goupille	Bolzen
4	MW430B03X013	1	Chiavetta	Key	Clavette	Keil
5	MFR66815	2	Fascia	Ring, top	Segment de piston	Ring
6	MBG03488	2	Fermo spinotto	Clip, piston pin	Segment d'arrêt	Sicherungsring
7	MFR66809	1	Cuscinetto a rulli	Bearing, needle	Roulement	Rollenlager
8	MZZ70028C	2	Dado	Nut, conical SPG	Écrou	Mutter

- 4 - VOLANO E BOBINA
- 4 - FLYWHEEL MAGNETO SYSTEM
- 4 - VOLANT ET BOBINE
- 4 - SCHWUNGRAD

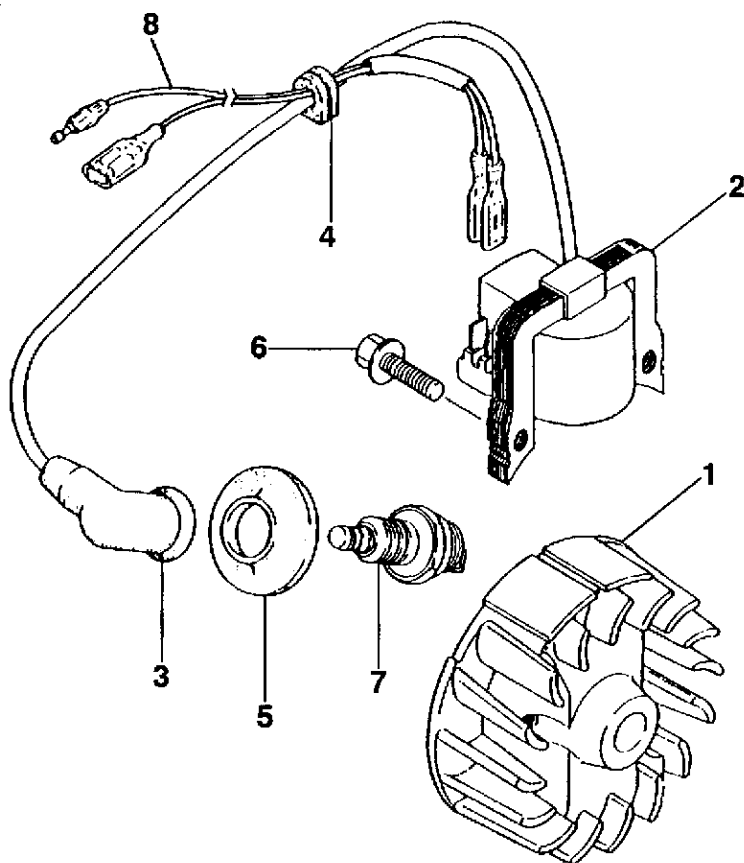

Nr.	Cod.	Q.ty	Descrizione	Description	Description	Beschreibung
1	MKE11016AA	1	Volano	Flywheel	Volant	Schwungrad
2	MKE04025AA	1	Bobina (incl. 3)	Coil, ignition (incl. 3)	Bobine (incl. 3)	Zündspule (incl. 3)
3	MFR64961	1	Cappuccio candela	Cap. plug	Capouchon de la bougie	Stecker
4	MKE90001BA	1	Gommino	Grommet	Protection	Schutz
5	MFR66751	1	Protezione	Cap. plug	Protection	Schutz
6	MFR64569A	2	Bullone	Bolt	Boulon	Schraube
7	MFR63087A	1	Candela NGK BM6A	Plug, spark NGK BM6A	Bougie NGK BM6A	Kerze NGK BM6A
8	MKE90106AA	1	Cavi	Wire, lead	Câbles	Kabel

INIEZIONE  
SISTEMA  
INIEZIONE  
INIEZIONE  
INIEZIONE

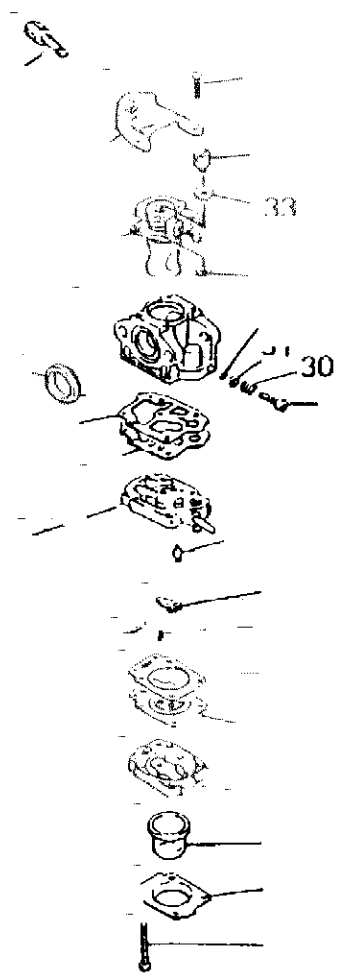
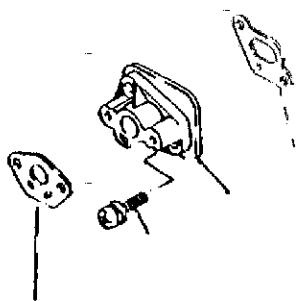

<u>Nr.</u>	<u>Cod.</u>	<u>Q.ty</u>	<u>Descrizione</u>	<u>Description</u>	<u>Description</u>	<u>Beschreibung</u>
1	MKW34042AA		Guarnizione	Gasket	Joint	Dichtung
2	MKK31018AA		Isolatore	insulator	Isolateur	Isolator
3	MFR64960A	2	Vite	Screw	Vis	Schraube
4	MKW39050AA		Guarnizione	Gasket	Joint	Dichtscheibe
5	MKK22017AA		Carburatore (incl.6-33)	Carburetor( incl.6-33)	Carburateur (incl. 6-33)	Vergaser (incl.6-33)
6	MKK22016AA002		Corpo pompa (incl.7-12)	Body, pump (incl. 7-12)	Corps de pompe (incl. 7-12)	Körper (incl. 7-12)
7	MKK21009AA002		Filtro	Screen	Filtre	Filter
8	MKK22007AA003		Spillo	Valve, needle	Pointeau	Nadelventil
9	MKK23002AA005		Molla	Spring	Ressort	Feder
10	MKK22007AA005		Vite	Screw	Vis	Schraube
11	MFR66652XX027		Spina	Pin	Goupille	Bolzen
12	MFR66652XX029		Leva	Lever	Levier	Hebel
13	MKK22007AA006		Corpo	Body	Corps	Körper
14	MKK22007AA007		Coperchio	Cover	Couvercle	Deckel
15	MKK21017AA013		Primer	Primer pump	Pompe carburation	Pumpe
16	MFR66652XX013		Membrana	Diaphragm	Membrane	Membran
17	MKK22007AA012		Guarnizione	Gasket	Joint	Dichtscheibe
18	MKK21017AA005		Membrana	Diaphragm	Membrane	Membran
19	MKK21017AA004		Guarnizione	Gasket	Joint	Dichtscheibe
20	MFR66652XX032		Fermo	Clip	Collier	Halter
21	MKK21024AA022		Ferma cavo	Holder, wire	Collier	Kabelhalter
22	MKK22008AA412		Valvola	Valve, throttle	Vanne à papillon	Klappe
23	MKK21017AA021	2	Vite	Screw	Vis	Schraube
24	MKK22023AA014		Supporto	Bracket	Support	Lager
25	MKK21017AA027		Dado	Nut	Écrou	Mutter
26	MKK21017AA126		Vite	Screw	Vis	Schraube
27	MKK21024AA014		Anello	Packing	Bague	Ring
28	MKK22007AA019	4	Vite	Screw	Vis	Schraube
29	MKK22007AA020		Vite H	Needle, high speed (H)	Vis haute vitesse (H)	Schraube (H)
30	MKK21021AA008		Molla	Spring	Ressort	Feder
31	MKK22007AA022		Rondella	Washer	Rondelle	Unterlegscheibe
32	MKK22007AA023	1	O-ring	O-ring	Joint torique	O-ring
33	MKK22004EA024		Rondella	Washer	Rondelle	Unterlegscheibe

- 6 - FILTRO ARIA
- 6 - AIR CLEANER SYSTEM
- 6 - FILTRE À AIR
- 6 - LUFTFILTER

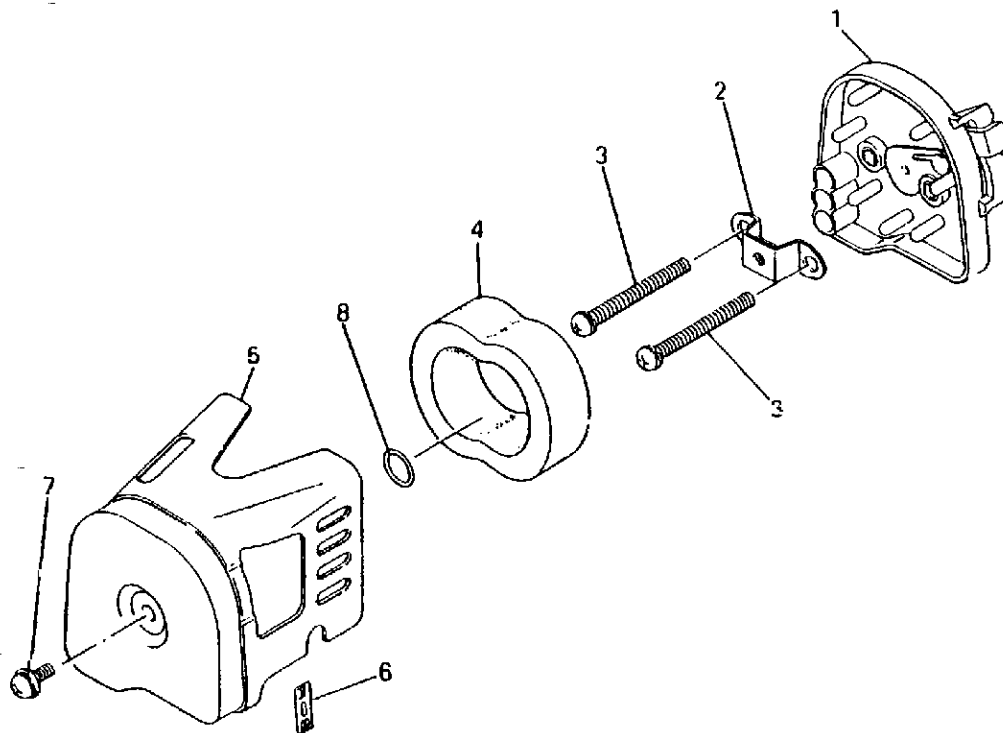

Nr.	Cod.	Q.ty	Descrizione	Description	Description	Beschreibung
1	MKA01053AA	1	Filtro aria	Air cleaner	Filtre à air	Luftfilter
2	MKA90064AA	1	Supporto	Bracket	Support	Lager
3	MH081D05X050	2	Vite	Screw	Vis	Schraube
4	MKA40045AA	1	Elemento	Element, cleaner	Filtre	Filtereinsatz
5	MKA20036AA	1	Coperchio filtro	Cover, cleaner	Couvercle	Deckel
6	MFR67555	1	Decalcomania	Decal	Autocollant	Abziehbild
7	MH071D05X012K	1	Vite	Screw	Vis	Schraube
8	MS655W04	1	O-ring	O-ring	Joint torique	O-ring



- 7 - MARMITTA
- 7 - MUFFLER SYSTEM
- 7 - BOÎTE D'ÉCHAPPEMENT
- 7 - SCHALLDÄMPFER

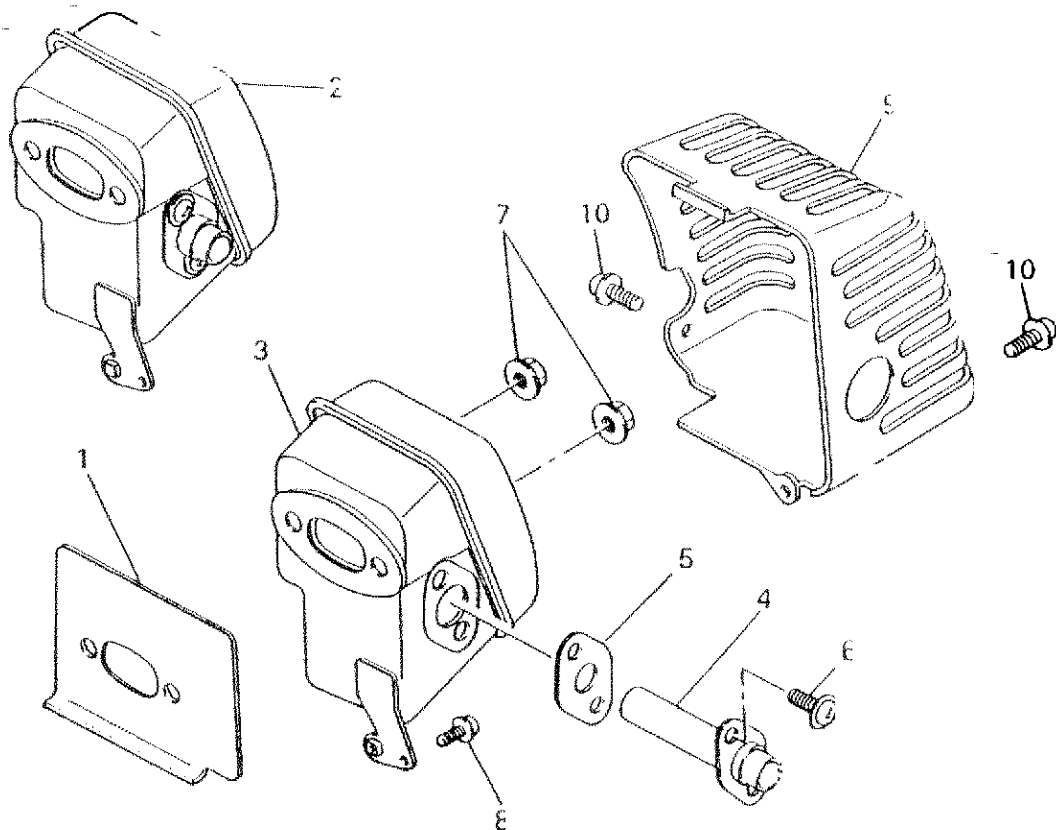

Nr.	Cod.	Q.ty	Descrizione	Description	Description	Beschreibung
1	MKM70028AA	1	Guarnizione	Gasket, muffler	Joint	Dichtscheibe
2	MKM01040AA	1	Marmitta (incl. 3-6)	Muffler (incl. 3-6)	Boîte d'échappement (incl. 3-6)	Schalldämpfer (incl. 3-6)
3	MKM01041AA		Marmitta	Muffler	Boîte d'échappement	Schalldämpfer
4	MKM50028AA		Tubo	Pipe, tail	Tuyau	Rhorleitung
5	MKM70022BA		Guarnizione	Gasket, muffler	Joint	Dichtscheibe
6	MKM01033AA004	2	Vite	Screw	Vis	Schraube
7	MFR67566	2	Dado	Nut, flange	Écrou	Mutter
8	MH071D05X012K	1	Vite	Screw	Vis	Schraube
9	MKM21006AA	1	Coperchio marmitta	Cover, muffler	Couvercle	Deckel
10	MKU12018AA	2	Vite	Screw	Vis	Schraube

- 8 - FRIZIONE
- 8 - CLUTCH SYSTEM
- 8 - EMBRAYAGE
- 8 - KUPPLUNG

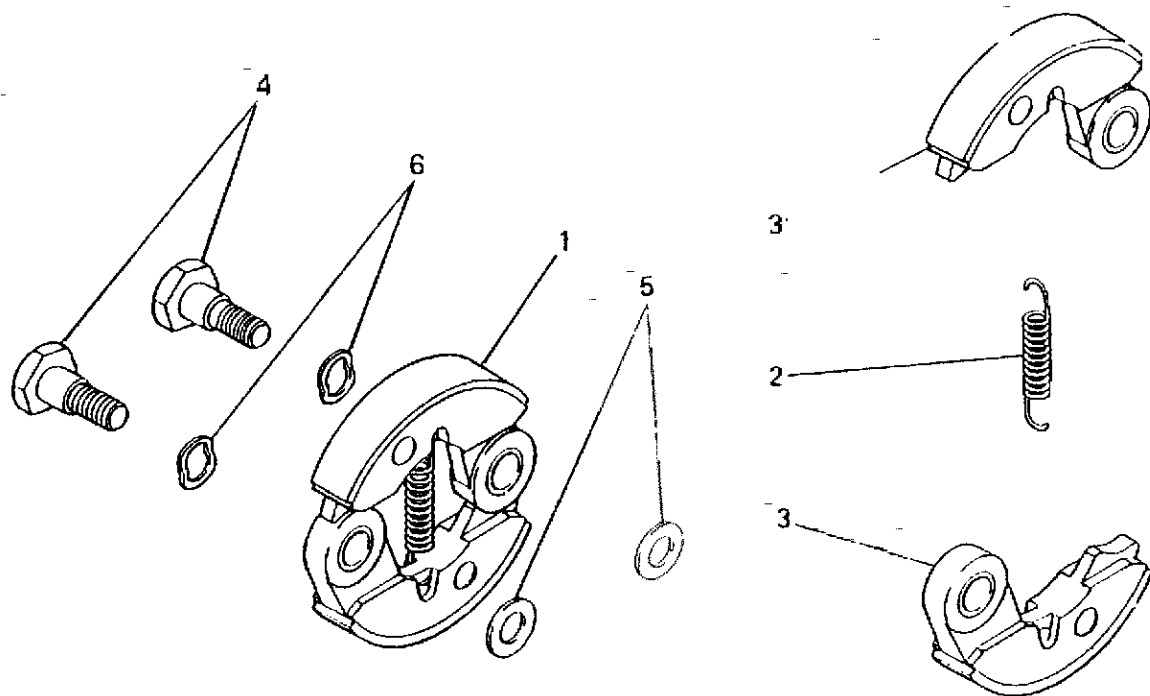

Nr.	Cod.	Q.ty	Descrizione	Description	Description	Beschreibung
1	MFR66843A	1	Frizione (incl. 2-3)	Clutch (incl. 2-3)	Embrayage (incl. 2-3)	
2	MKU80010AA	1	Molla	Spring	Ressort	
3	MKT12002BA	2	Scarpa frizione	Shoe, clutch	Mâchoire d'embrayage	
4	MKT14001AA	2	Bullone frizione	Bolt, clutch	Boulon	
5	MFR67347	2	Ranella	Washer	Rondelle	
6	MKU36001AA	2	Ranella	Washer	Rondelle	

- 9 - AVVIAMENTO
- 9 - RECOIL STARTER SYSTEM
- 9 - DÉMARREUR À MAIN
- 9 - ANLASSEN VON HAND

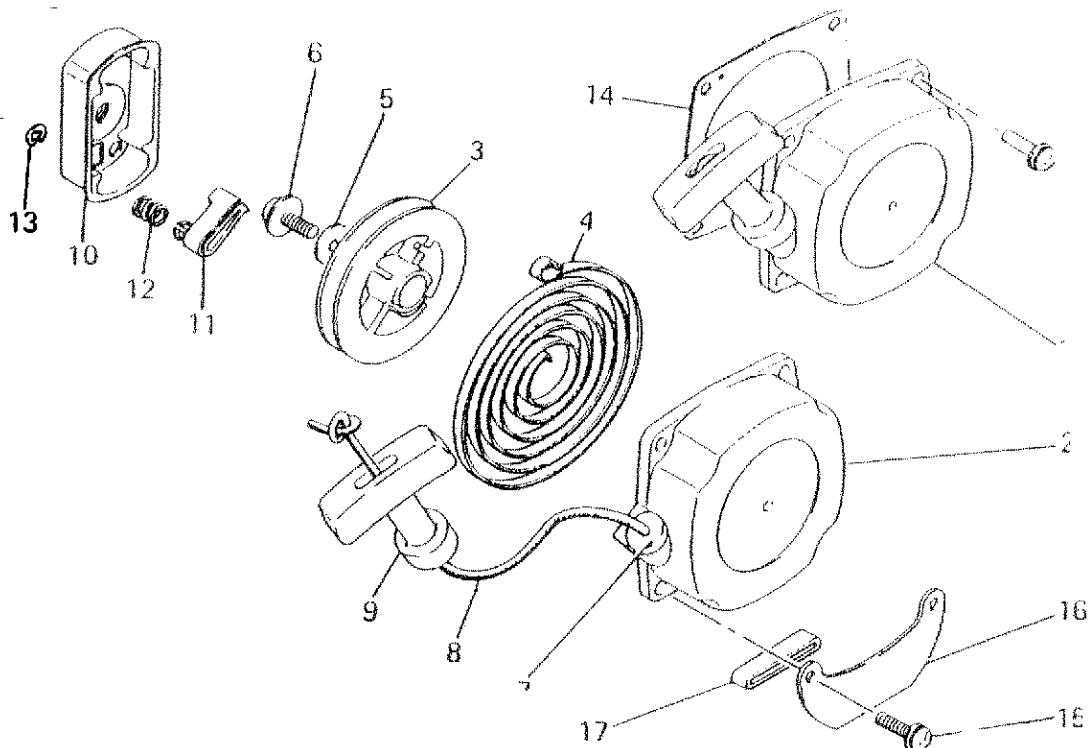

Nr.	Cod.	Q.ty	Descrizione	Description	Description	Beschreibung
1	MKS02037AA	1	Avviamento (incl. 2-9)	Recoil starter (incl. 2-9)	Démarreur à main (incl. 2-9)	Anlassen von Hand (incl. 2-9)
2	MKS02037AA001	1	Carter avviamento	Case, starter	Boîtier	Gehäuse
3	MKS02037AA002	1	Puleggia	Reel	Poulie	Riemenscheibe
4	MKS02037AA003	1	Molla	Spring	Ressort	Feder
5	MKS02037AA004	1	Rondella	Washer	Rondelle	Unterlegscheibe
6	MKS02037AA005	1	Vite	Screw	Vis	Schraube
7	MKS20021AA006	1	Guida corda	Guide	Guide	Fuehrung
8	MKS02037AA008	1	Corda avviamento	Rope, starter	Corde	Schnur
9	MFR66881XX011	1	Manopola	Knob, Starter	Poignée	Griff
10	MKS03004BA	1	Innesto (incl.11-13)	Cover (incl.11-13)	Couvercle (incl.11-13)	Deckel (incl.11-13)
11	MKS03004AA002	1	Saltarello	Ratchet	Crochet	Spermocken
12	MKS03004BA103	1	Molla	Spring, return	Ressort	Feder
13	MKS03004AA004	1	Fermo	Snap ring	Collier	Halter
14	MKS90023AA	1	Piastra	Plate	Plaque	Platte
15	MKU12018CA	3	Vite	Screw	Vis	Schraube
16	MKF09017AA	1	Supporto (incl. 17)	Bracket (incl.17)	Support (incl. 17)	Halter(incl. 17)
17	MKF80004AA	1	Gommino	Pad	Épaisseur en caoutchouc	Distanzbüchse

10 - SERBATOIO  
 10 - FUEL TANK SYSTEM  
 10 - RÉSERVOIR  
 10 - TANK

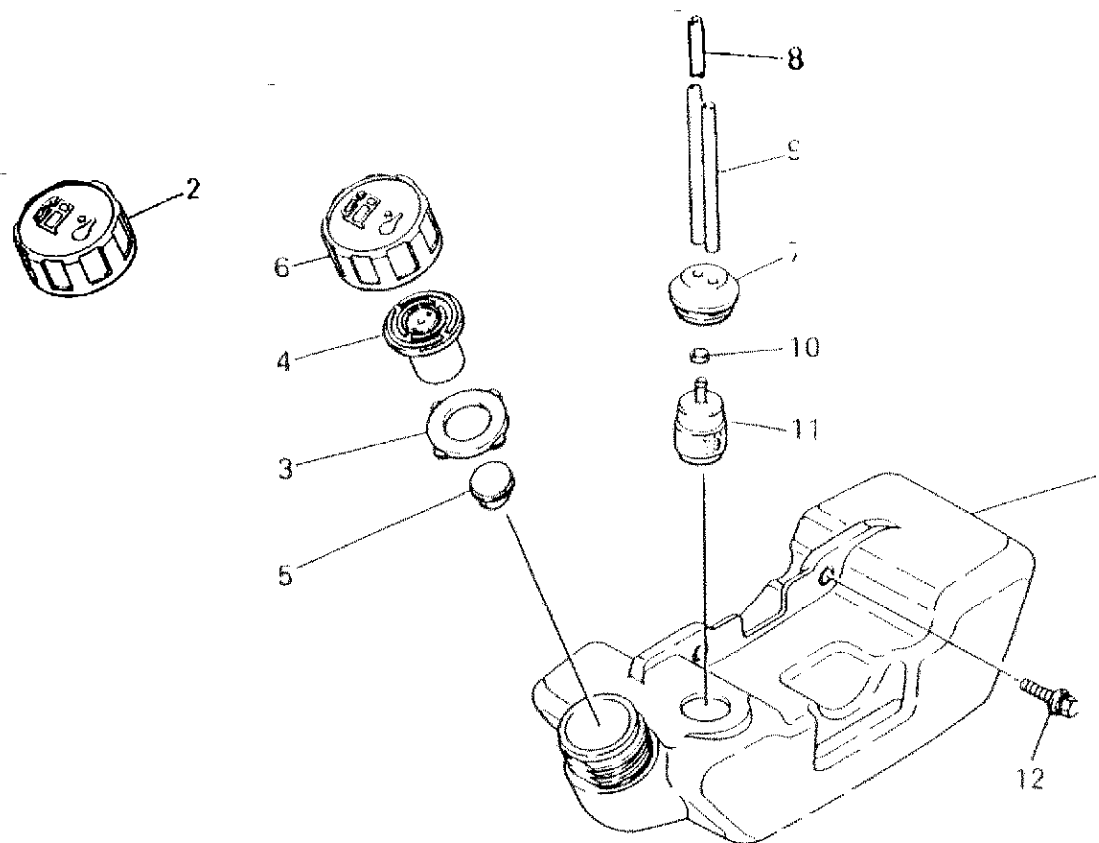

Nr.	Cod.	Q.ty	Descrizione	Description	Description	Beschreibung
1	MKF01064AA	1	Serbatoio (incl. 2-11)	Tank assy (incl. 2-11)	Réservoir (incl. 2-11)	Tank (incl. 2-11)
2	MKF05014AA	1	Tappo( incl. 3-6)	Cap assy (incl. 3-6)	Bouchon (incl. 3-6)	Tankverschluss
3	MKF90049AA	1	Paraolio	Packing	Joint	Dichtscheibe
4	MKF09011AA	1	Valvola	Valve, breather	Soupape	Ventil
5	MKF90050AB	1	Tappo	Cap	Bouchon	Stopfen
6	MKF21012AA	1	Tappo serbatoio	Cap, fuel tank	Bouchon du réservoir	Tankverschluss
7	MKF90048AA	1	Tappo	Plug	Bouchon	Stopfen
8	MFR67142XX001	1	Tubo miscela	Tube, fuel	Tube carburant	Brennstoffleitung
9	MFR64255F	1	Tubo miscela	Tube, fuel	Tube carburant	Brennstoffleitung
10	MKF01033AA007	1	Bussola	Bushing	Bague	Buchse
11	MKF40004AA	1	Filtro carburante	Filter, fuel	Filtre carburant	Filter
12	MKU12016AA	2	Bullone	Bolt	Boulon	Schraube

- 11 - CARTER FRIZIONE
- 11 - CLUTCH CASE
- 11 - BOÎTIER D'EMBRAYAGE
- 11 - KUPPLUNG KASTEN

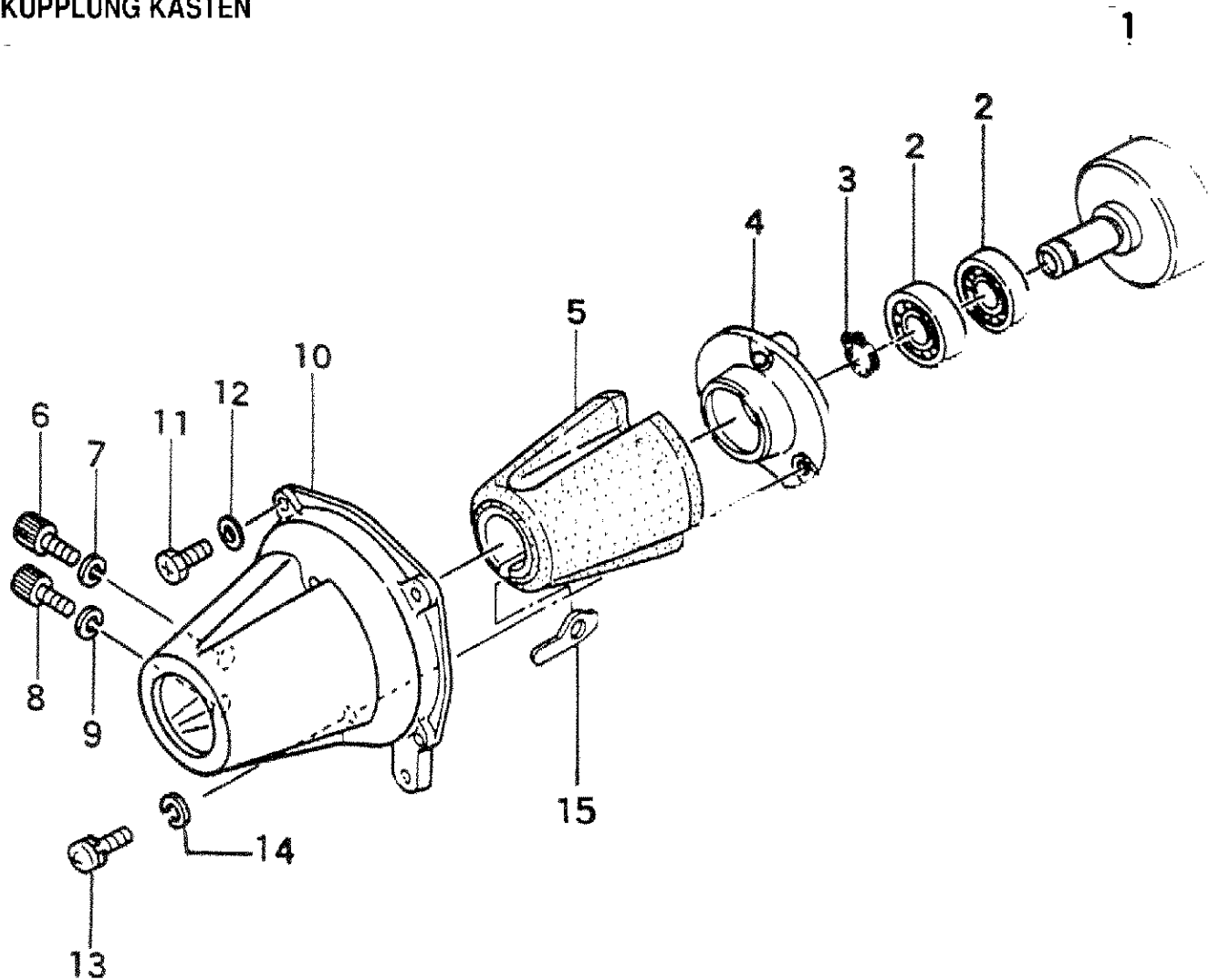

Nr.	Cod.	Q.ty	Descrizione	Description	Description	Beschreibung
1	P289-0143C-800B	1	Campana frizione	Clutch, drum	Entraîneur	Trommel
2	P999-61600-102	2	Cuscinetto	Bearing	Roulement	Lager
3	1070001A1	1	Seeger	Stop ring	Seeger	Seeger
4	P374-0631A-20	1	Flangia	Flange	Bride	Flansch
5	P599-0165A-80	1	Antivibrante	Cushion, rubber	Amortiseur	Schwingungsdämpfer
6	P990-51050-103	2	Vite	Screw	Vis	Schraube
7	P1020056	1	Rondella	Washer	Rondelle	Unterlegscheibe
8	P990-51050-203	1	Vite	Screw	Vis	Schraube
9	P1020056	1	Rondella	Washer	Rondelle	Unterlegscheibe
10	P331-33684-20GR	1	Carter frizione	Clutch, case	Boîtier d'embrayage	Kupplung kasten
11	P1010261	4	Vite	Screw	Vis	Schraube
12	1020008A1	4	Rondella	Washer	Rondelle	Unterlegscheibe
13	P1010207	3	Vite	Screw	Vis	Schraube
14	P1020056	3	Rondella	Washer	Rondelle	Unterlegscheibe
15	P249-0165A-21	1	Piastrina	Plate	Plaque	Platte

- 12 - ASTA CON IMPUGNATURA SINGOLA
- 12 - SHAFT WITH SINGLE HANDLE
- 12 - ARBRE DE TRANSMISSION AVEC PORTAGE ANNEAU
- 12 - ANTRIEBSWELLE + EINFACHGRIFF

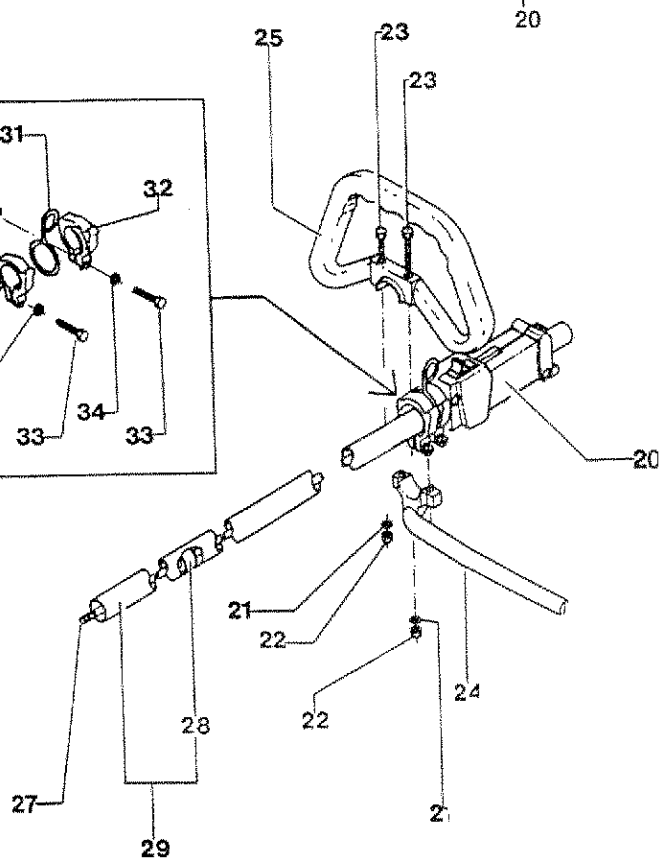
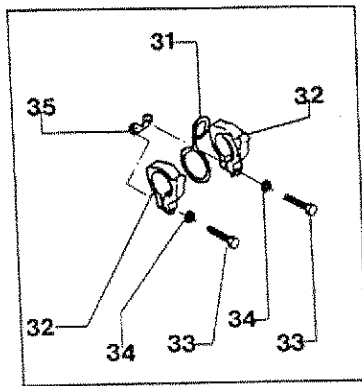
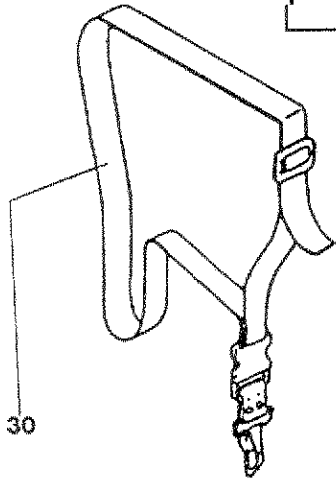
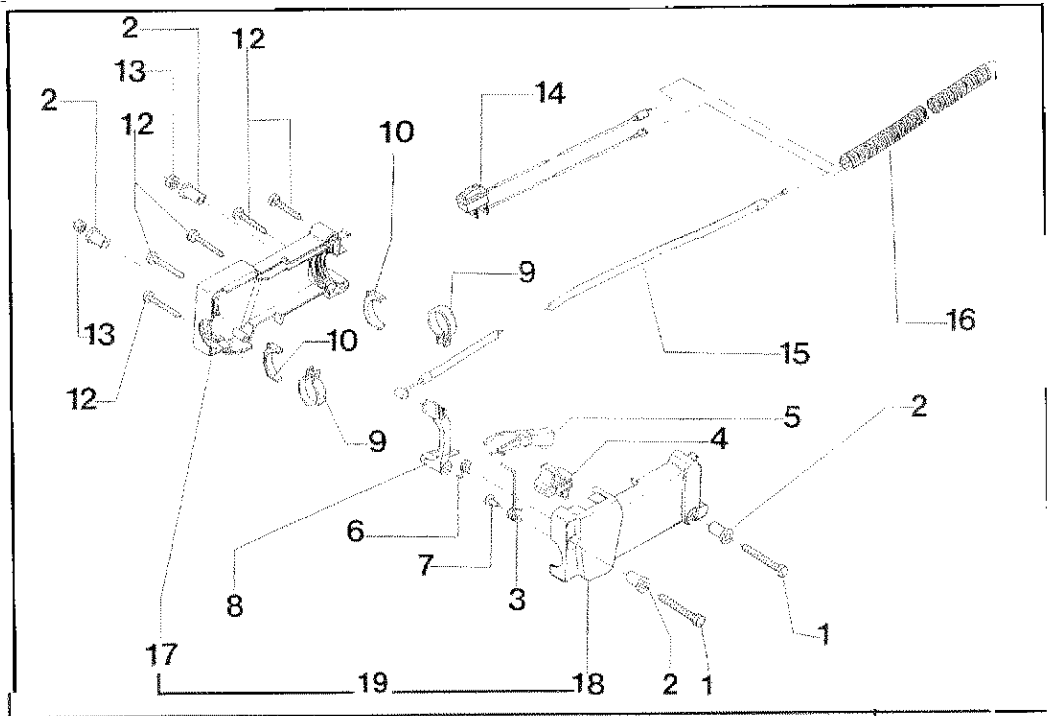

Nr.	Cod.	Q.ty	Descrizione	Description	Description	Beschreibung
1	1010002A1	2	Vite	Screw	Vis	Schraube
2	P3040320ZT	4	Bussola	Bushing	Bague	Buchse
3	P3020037ZT	1	Molla per pulsante	Spring	Ressort	Feder
4	P2020406R	1	Pulsante 1/2 gas	Half throttle button	Bouton de demi-gaz	Schlossdrucktaster
5	P2020388R	1	Leva di bloccaggio	Lever	Levier	Hebel
6	P3020036ZT	1	Molla	Spring	Ressort	Feder
7	P1020109	1	Ribattino	Rivet	Rivet	Niet
8	P2020409R	1	Leva acceleratore	Throttle lever	Levier de l'accélérateur	Gashebel
9	P4010243ZT	2	Fascetta	Clamp	Collier	Rapband
10	P2020385	4	Riduzione	Réduction	Réduction	Reduktion
12	P1010216	5	Vite	Screw	Vis	Schraube
13	1050002A1	2	Dado	Nut	Écrou	Mutter
14	P5080035	1	Interruttore completo	Switch assy	Interrupteur complet	Steuerung
15	P5020098	1	Cavo acceleratore	Throttle wire	Câble de l'accélérateur	Gaskabel
16	P164-10016-80	mt. 0,19	Guaina	Protection tube	Protection	Schutz
17			Vedi Nr 19	See Nr. 19	Voir Nr. 19	Siehe Nr. 19
18			Vedi Nr 19	See Nr. 19	Voir Nr. 19	Siehe Nr. 19
19	P2020417	1	Impugnatura	Handle	Portage	Steuerung
20	P3080043	1	Impugnatura compl.	Handle assy	Portage complet	Steuerung komp.
21	1020013A1	2	Rondella	Washer	Rondelle	Unterlegscheibe
22	1050003A1	2	Dado	Nut	Écrou	Mutter
23	P1010226	2	Vite	Screw	Vis	Schraube
24	P2020394	1	Asta di protezione	Protection shaft	Tige de protection	Stange
25	P500-35560-20	1	Manico asta	Handle	Portage anneau	Griff
27	P343-33699-21	1	Albero trasmissione	Drive shaft	Arbre de transmission	Antriebswelle
28	P20200414	5	Gommino	Bushing	Douille	Büchse
29	P2090008	1	Asta con gommino	Drive shaft	Arbre de transmission	Antriebswelle
30	P746-33407-90	1	Bretelle	Harness	Bandoulière	Schultergurt
31	P335-37307-20	1	Supporto bretelle	Suspension hook	Métal de levage	Halterarm
32	P334-37352-21	2	Fermo supporto	Lifting metal collar	Collier de levage	Sperrung
33	P990-51050-303	2	Vite	Screw	Vis	Schraube
34	P992-01050-061	2	Rondella	Washer	Rondelle	Unterlegscheibe
35	P315-37304-20	1	Piastrina	Plate	Plaque	Platte

- 13 - ASTA CON IMPUGNATURA DOPPIA
- 13 - SHAFT WITH DOUBLE HANDLE
- 13 - ARBRE DE TRANSMISSION AVEC PORTAGE MANCHERONS
- 13 - ANTRIEBSWELLE + DOPPELGRIFF

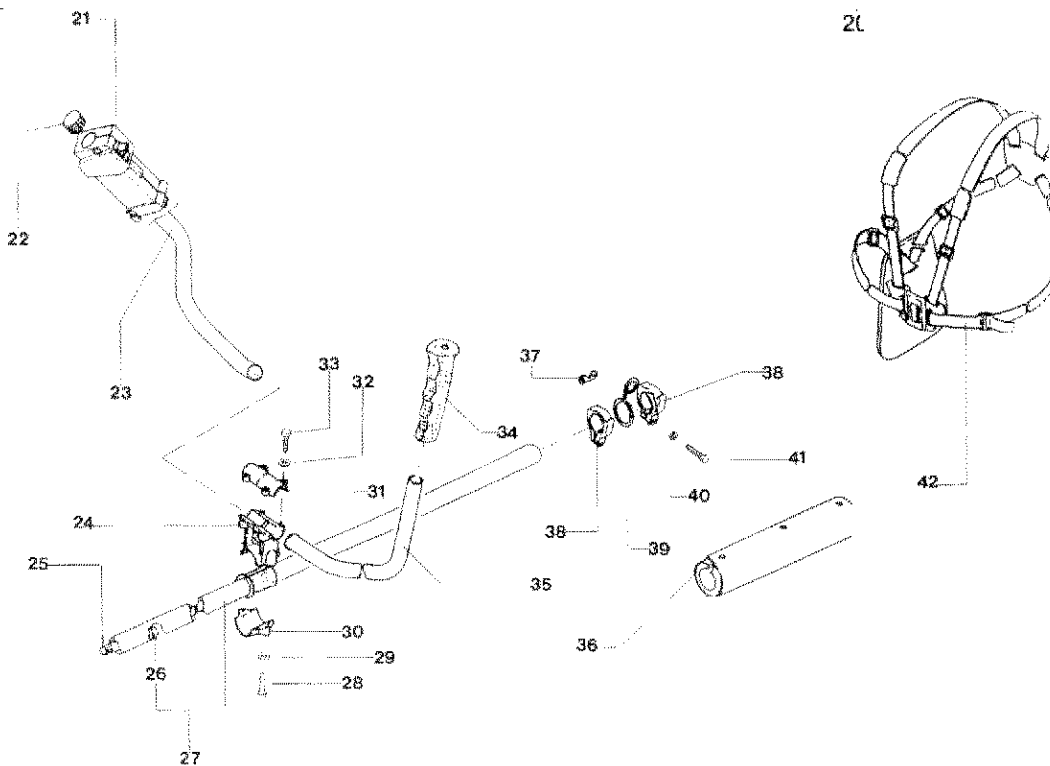
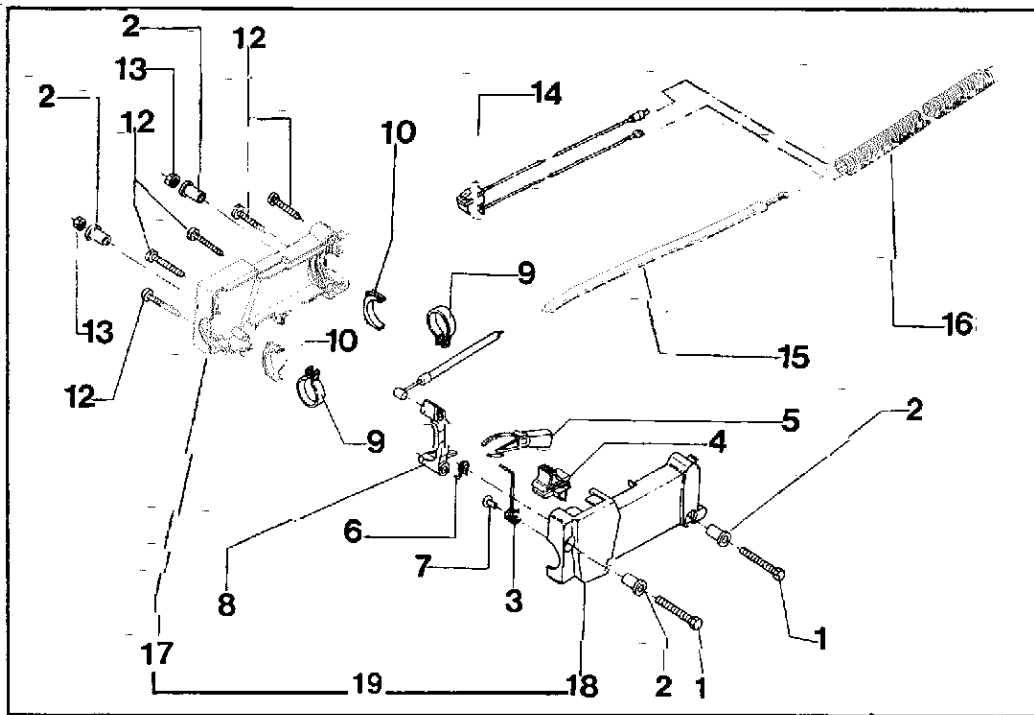



Nr.	Cod.	Q.ty	Descrizione	Description	Description	Beschreibung
1	1010002A1	2	Vite	Screw	Vis	Schraube
2	P3040320ZT	4	Bussola	Bushing	Bague	Buchse
3	P3020037ZT	1	Molla per pulsante	Spring	Ressort	Feder
4	P2020406R	1	Pulsante 1/2 gas	Half throttle button	Bouton de demi-gaz	Schlossdrucktaster
5	P2020388R	1	Leva di bloccaggio	Lever	Levier	Hebel
6	P3020036ZT	1	Molla	Spring	Ressort	Feder
7	P1020109	1	Ribattino	Rivet	Rivet	Niet
8	P2020409R	1	Leva acceleratore	Throttle lever	Levier de l'accélérateur	Gashebel
9	P4010244ZT	2	Fascetta	Clamp	Collier	Rapband
10	P2020384	4	Riduzione	Reduction	Réduction	Reduktion
12	P1010216	5	Vite	Screw	Vis	Schraube
13	1050002A1	2	Dado	Nut	Écrou	Mutter
14	P5080036	1	Interruttore completo	Switch assy	Interrupteur complet	Steuerung komp.
15	P5020084	1	Cavo acceleratore	Throttle wire	Câble de l'accélérateur	Gaskabel
16	P164-10016-80	mt. 0,70	Guaina	Protection tube	Protection	Schutz
17			Vedi Nr 19	See Nr. 19	Voir Nr. 19	Siehe Nr. 19
18			Vedi Nr 19	See Nr. 19	Voir Nr. 19	Siehe Nr. 19
19	P2020417	1	Impugnatura	Handle	Portage	Steuerung
20	P3080041	1	Impugnatura compl.	Handle assy	Portage complet	Steuerung komp.
22	P5060012	1	Tappo	Plug	Bouchon	Stopfen
23	P3120119ZT	1	Tubo dx	Tube, r.h.	Tuyau droit	Rhorleitung r.
24	P507-37623-20GR	1	Supporto manico	Handle holder	Support du portage	Halter
25	P343-33699-21	1	Albero trasmissione	Drive shaft	Arbre de transmission	Antriebswelle
26	P2090014	5	Gommino	Bushing	Douille	Büchse
27	P2090008	1	Asta con gommino	Drive shaft	Arbre de transmission	Antriebswelle
28	P990-53060-253	2	Vite	Screw	Vis	Schraube
29	1020008A1	2	Rondella	Washer	Rondelle	Unterlegscheibe
30	P508-37623-20GR	1	Supporto manico inf.	Handle holder, lower	Support inf.	Halter
31	P506-37623-20GR	1	Supporto manico sup.	Handle holder, upper	Support sup.	Halter
32	P1020056	4	Rondella	Washer	Rondelle	Unterlegscheibe
33	P990-51050-303	4	Vite	Screw	Vis	Schraube
34	P165-33130-20	1	Manopola	Handle	Manchon	Griff
35	P502-33674-20	1	Tubo sx	Tube, l.h.	Tuyau gauche	Rhorleitung l.
36	P336-33411-82	1	Protezione cavi	Cable protection	Protection	Protektion
37	P315-37304-20	1	Piastrina	Plate	Plaque	Platte
38	P334-37352-21	2	Fermo supporto	Lifting metal collar	Collier de levage	Sperrung
39	P335-37307-20	1	Supporto bretella	Suspension hook	Métal de levage	Halterarm
40	P992-01050-061	2	Rondella	Washer	Rondelle	Unterlegscheibe
41	P990-51050-303	2	Vite	Screw	Vis	Schraube
42	P746-37455-90	1	Bretella	Harness	Bandoulière	Schultergurt

- 14 - COPPIA CONICA
- 14 - GEAR CASE
- 14 - CARTER D'ENGRENAGE
- 14 - KEGELRADERPAARUNG

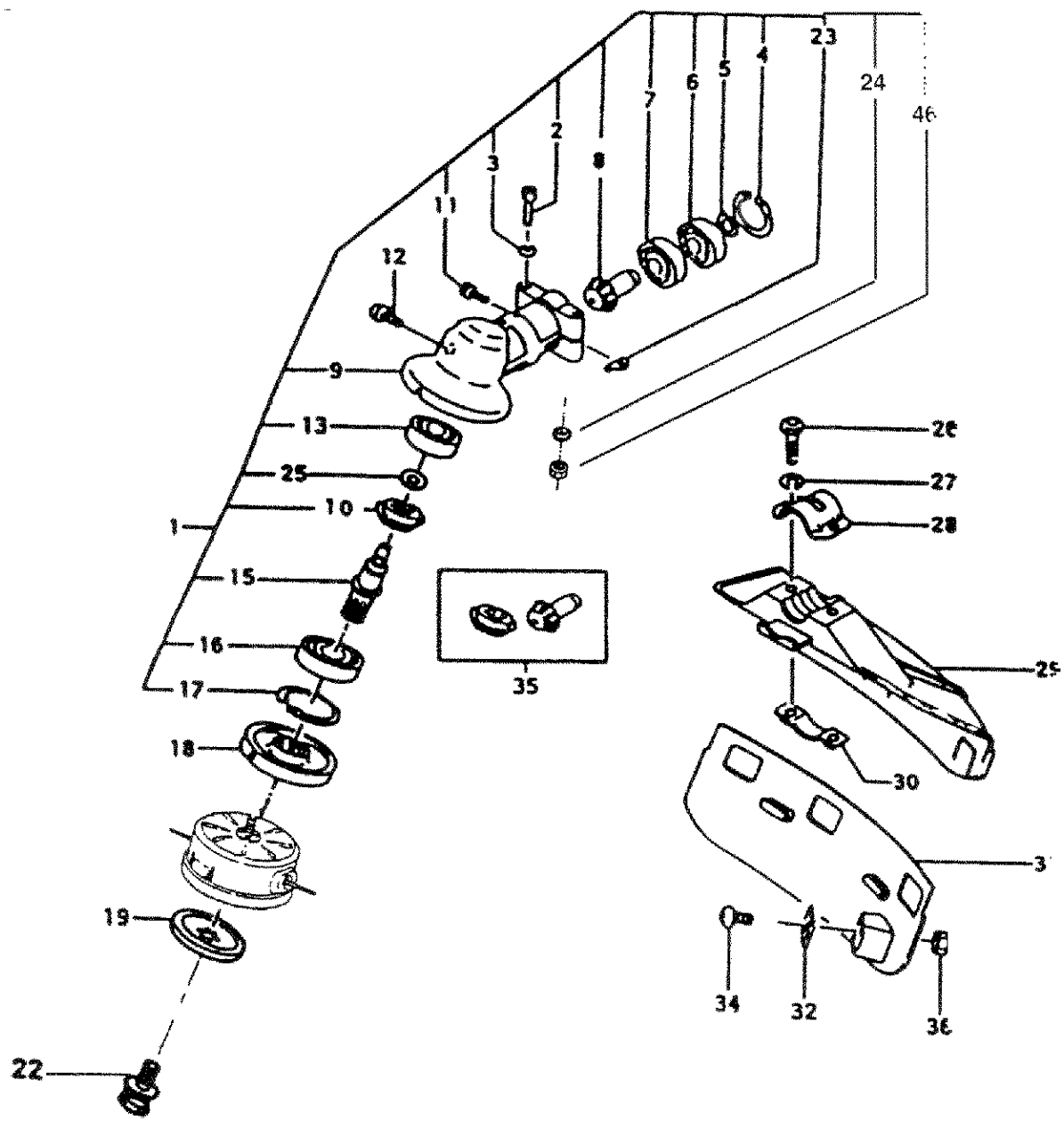

Nr.	Cod.	Q.ty	Descrizione	Description	Description	Beschreibung
1	P300-37134-90		Scatola completa	Gear case assy	Carter d'engrenage comp.	Kegeltrieb komp.
2	P1010235	2	Vite	Screw	Vis	Schraube
3	P1020056	2	Rondella	Washer	Rondelle	Unterlegscheibe
4	P993-51024-002		Seeger	Stop ring	Seeger	Seeger
5	P993-50009-002		Seeger	Stop ring	Seeger	Seeger
6	P999-61609-002		Cuscinetto	Bearing	Roulement	Lager
7	P999-61609-000		Cuscinetto	Bearing	Roulement	Lager
8			Vedi Nr. 35	See Nr. 35	Voir Nr. 35	Siehe Nr. 35
9	P300-3330B-20GR		Carter testina	Gear case	Carter d'engrenage	Kasten
10			Vedi Nr. 35	See Nr. 35	Voir Nr. 35	Siehe Nr. 35
11	P990-51050-103		Vite	Screw	Vis	Schraube
12	P990-15080-100		Vite	Screw	Vis	Schraube
13	P999-61628-000		Cuscinetto	Bearing	Roulement	Lager
15	P304-37134-200		Alberino	Shaft	Arbre	Welle
16	P999-61620-103		Cuscinetto	Bearing	Roulement	Lager
17	P1070013		Seeger	Stop ring	Seeger	Seeger
18	P310-37623-20	1	Supporto sup. lama	Cutter holder	Support de lame	Halter
19	P311-37300-20	1	Supporto inf. lama	Cutter holder	Support de lame	Halter
22	P312-33386-20	1	Vite	Screw	Vis	Schraube
23	P992-01050-061	1	Rondella	Washer	Rondelle	Unterlegscheibe
24	P1020055	2	Rondella	Washer	Rondelle	Unterlegscheibe
25	P067-37134-20	1	Rondella	Washer	Rondelle	Unterlegscheibe
26	P1010261	2	Vite	Screw	Vis	Schraube
27	1020008A1	2	Rondella	Washer	Rondelle	Unterlegscheibe
28	P442-37380-20	1	Supporto sup.	Bracket, upper	Support sup.	Lager
29	P2020403NE	1	Protezione sup.	Safety guard	Couvercle de sécurité	Schutz
30	P445-37380-20		Supporto inf.	Bracket, lower	Support inf.	Lager
31	P2020404NE		Protezione inf.	Safety guard	Couvercle de sécurité	Schutz
32	P4010353BR		Coltello taglia filo	Wire cutter	Lame de coupage fil	Schneide
34	P994-14050-121		Vite	Screw	Vis	Schraube
35	P2090011		Coppia conica	Gear assy	Couple conique	Kegelraderpaarung
36	1050002A1		Dado	Nut	Écrou	Mutter
46	1050002A1	2	Dado	Nut	Écrou	Mutter

- 1 - GRUPPO CASSA
- 1 - CRANKCASE SYSTEM
- 1 - BOÎTIER
- 1 - GEHÄUSE

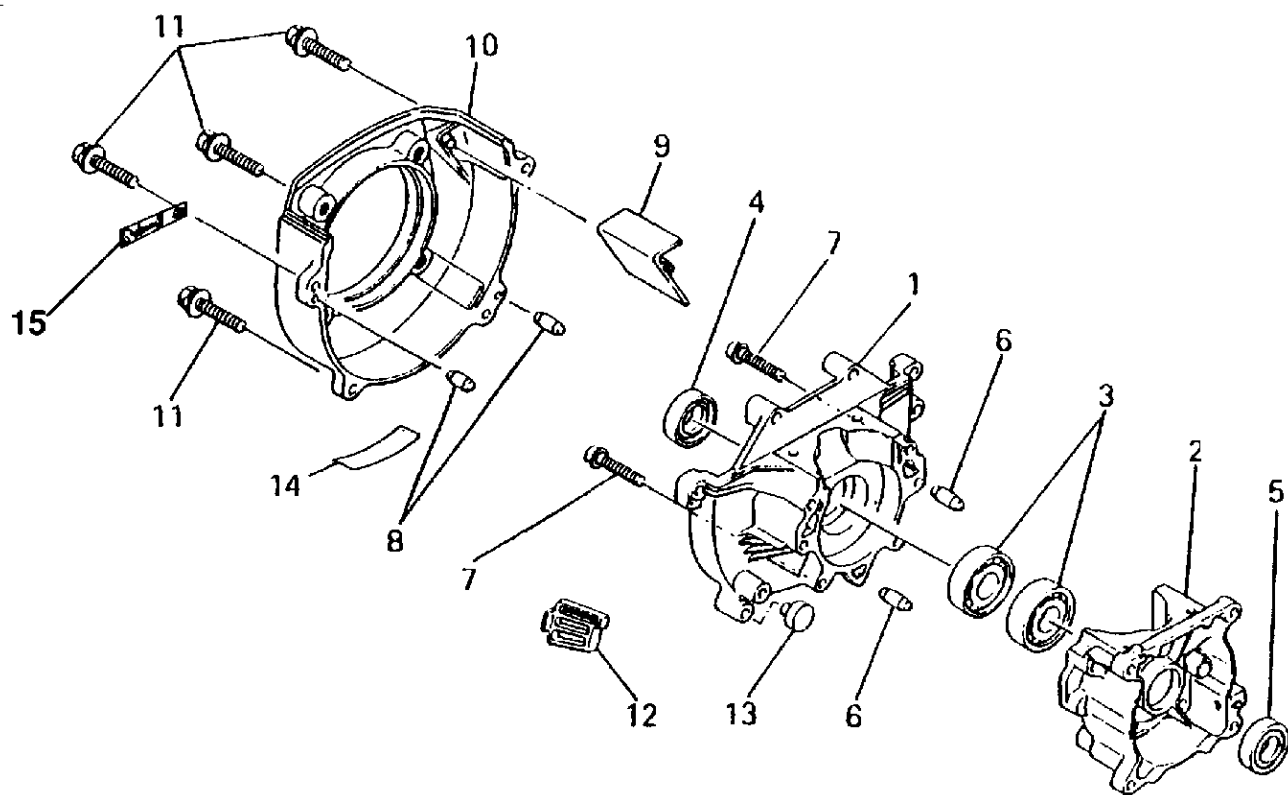

Nr.	Cod.	Q.ty	Descrizione	Description	Description	Beschreibung
1	MKB14004AA	1	Carter motore	Case, drive	Boîtier	Gehäuse
2	MKB14005AA	1	Cassa motore	Case, starter	Boîtier	Gehäuse
3	MS111X62X010	2	Cuscinetto a sfera	Bearing, ball	Roulement	Lager
4	MFR64230	1	Paraolio	Seal oil	Joint torique	Dichtring
5	MKW21005AA	1	Paraolio	Seal oil	Joint torique	Dichtring
6	MKU40003AA	2	Spina	Pin, dowel	Goupille	Bolzen
7	MH081D05X025	4	Vite	Screw	Vis	Schraube
8	MKU40004AA	2	Spina	Pin, dowel	Goupille	Bolzen
9	MKH90021AA	1	Protezione	Protection	Protection	Schutz
10	MKH30018AA	1	Carter motore	Case, fan	Boîtier	Gehäuse
11	MFR64569F	4	Bullone	Bolt	Boulon	Schraube
12	MKH90025AA	1	Coperchio	Cover	Couvercle	Deckel
13	MKF80005AA	2	Gommino	Pad	Épaisseur en caoutchouc	Distanzbüchse
14	MKW56056AA	1	Decalcomania	Decal	Autocollant	Abziehbild
15	MKU60001AA	1	Fermo	Clamp	Collier	Klammer