

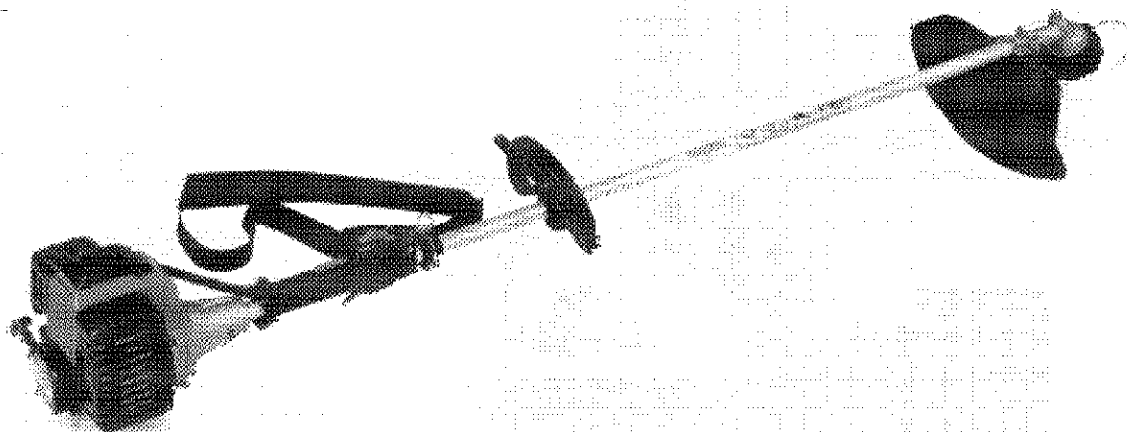

Stampato nr. / Form no.
Imprimé no. / Drucksachen Nr.
P5090269

**LISTA RICAMBI
SPARE PARTS LIST
LISTE DES PIÈCES DE RECHANGE
ERSATZTEILLISTE**



**DECESPUGLIATORE
BRUSH CUTTER
DÉBROUSSAILLEUSE
FREISCHNEIDER**

MBC 200

- 4 - DECALCOMANIE E ATTREZZI
- 4 - DECALS AND TOOLS
- 4 - AUTOCOLLANTS ET OUTILLAGE
- 4 - ABZIEHBILD

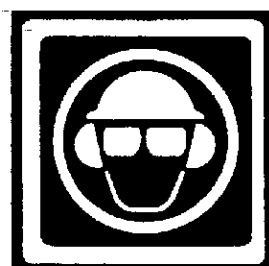
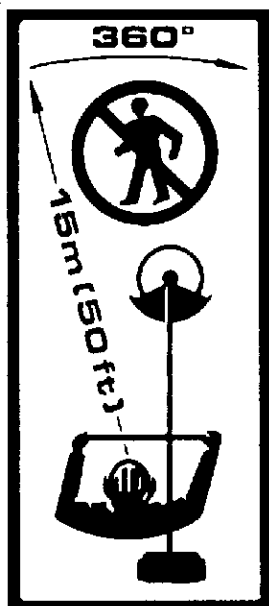

1



2



3

Nr.	Cod.	Q.ty	Descrizione	Description	Description	Beschreibung
1	P920-37504-200	1	Decalcomania	Decal	Autocollant	Abziehbild
2	P5140708	1	Decalcomania	Decal	Autocollant	Abziehbild
3	P5140701	1	Decalcomania	Decal	Autocollant	Abziehbild
	P5110018	1	Chiave a brugola	Allen wrench	Clé	Schlüssel
	P5110024	1	Chiave 13/19	Spanner 13/19	Clé 13/19	Schlüssel 13/19

2 - CILINDRO
 2 - CYLINDER
 2 - CYLINDRE
 2 - ZYLINDER

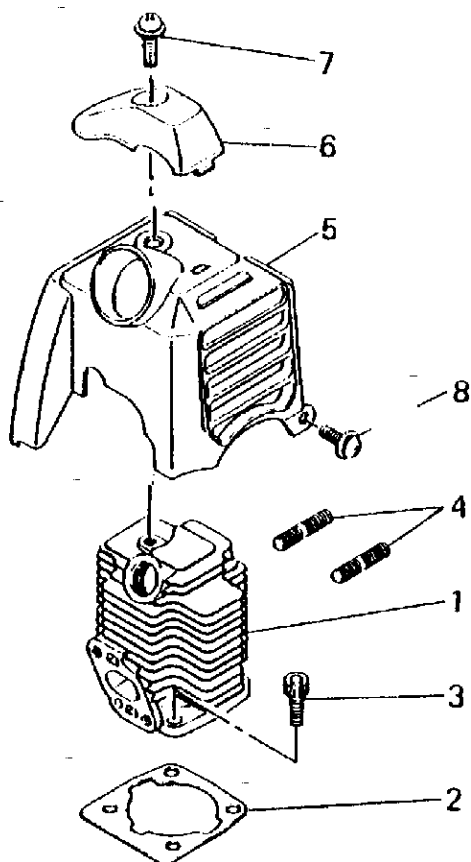

Nr.	Cod.	Q.ty	Descrizione	Description	Description	Beschreibung
1	MKC13008AA	1	Cilindro	Cylinder	Cylindre	Zylinder
2	MKW32010AA	1	Guarnizione cilindro	Gasket, cylinder	Joint	Dichtscheibe
3	MB121C05X016	4	Bullone	Bolt	Boulon	Schraube
4	MB151B05X040	2	Prigioniero	Bolt, stud	Goujon	Stehbolzen
5	MKH40028AA	1	Coperchio cilindro	Cover, cylinder	Couvercle	Deckel
6	MKH70010AA	1	Protezione	Guard, plug	Protection	Schutz
7	MH071D05X016K	1	Vite	Screw	Vis	Schraube
8	MKU12018BA	1	Vite	Screw	Vis	Schraube

- 3 - ALBERO MOTORE E PISTONE
- 3 - CRANKSHAFT & PISTON SYSTEM
- 3 - ARBRE MOTEUR ET PISTON
- 3 - KURBELWELLE

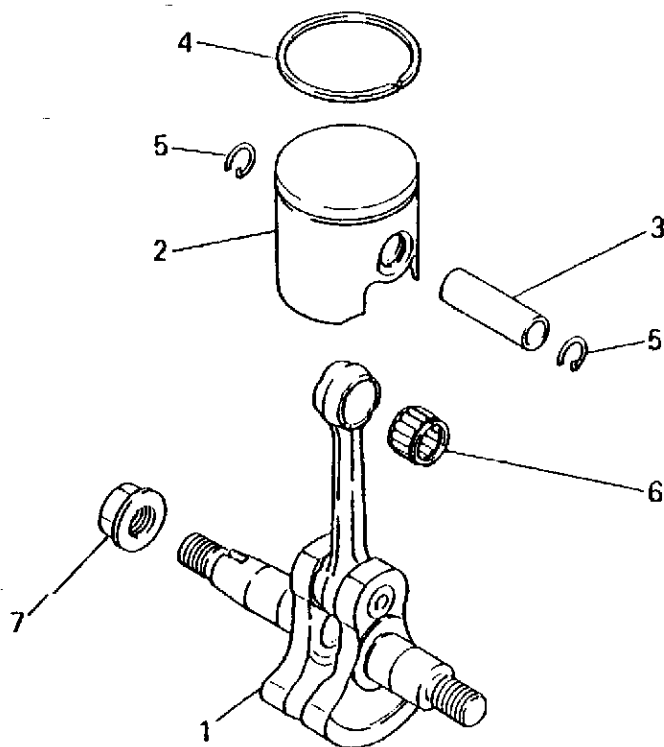

Nr.	Cod.	Q.ty	Descrizione	Description	Description	Beschreibung
1	MKD01021AA	1	Albero motore	Crankshaft	Arbre moteur	Kurbelwelle
2	MKP01027AA	1	Pistone (incl. 3)	Piston set (incl. 3)	Piston (incl. 3)	Kolben (incl. 3)
3	MKP51007AA	1	Spinotto	Pin, piston	Axe du piston	Bolzen
4	MKP23003AA	1	Fascia	Ring, top	Segment du piston	Ring
5	MFR67131	2	Fermo spinotto	Clip, piston pin	Segment d'arrêt	Sicherungsring
6	MFR67153	1	Cuscinetto a rulli	Bearing, needle	Roulement	Rollenlager
7	MZZ70028B	1	Dado	Nut, conical SPG	Écrou	Mutter

- 4 - VOLANO E BOBINA
- 4 - FLYWHEEL MAGNETO SYSTEM
- 4 - VOLANT ET BOBINE
- 4 - SCHWUNGRAD

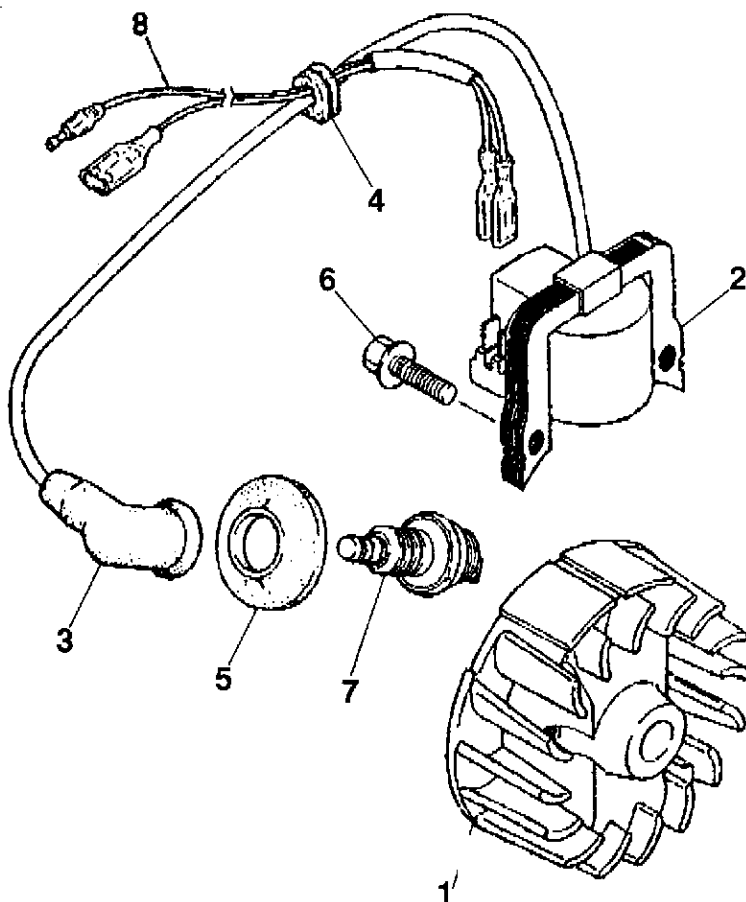

Nr.	Cod.	Q.ty	Descrizione	Description	Description	Beschreibung
1	MKE11010AA	1	Volano	Flywheel	Volant	Schwungrad
2	MKE04023AA	1	Bobina	Coil, ignition	Bobine	Zündspule
3	MFR64961	1	Cappuccio candela	Cap, plug	Capuchon de la bougie	Stecker
4	MKE90001BA	1	Gommino	Grommet	Protection	Schutz
5	MFR66751	1	Protezione	Cap, plug	Protection	Schutz
6	MFR64569A	2	Bullone	Bolt	Boulon	Schraube
7	MFR63087A	1	Candela NGK BM6A	Plug, spark NGK BM6A	Bougie NGK BM6A	Kerze NGK BM6A
8	MKE90106AA	1	Cavi	Wire, lead	Câbles	Kabel

- 5 - CARBURATORE
- 5 - CARBURETOR SYSTEM
- 5 - CARBURATEUR
- 5 - VERGASER

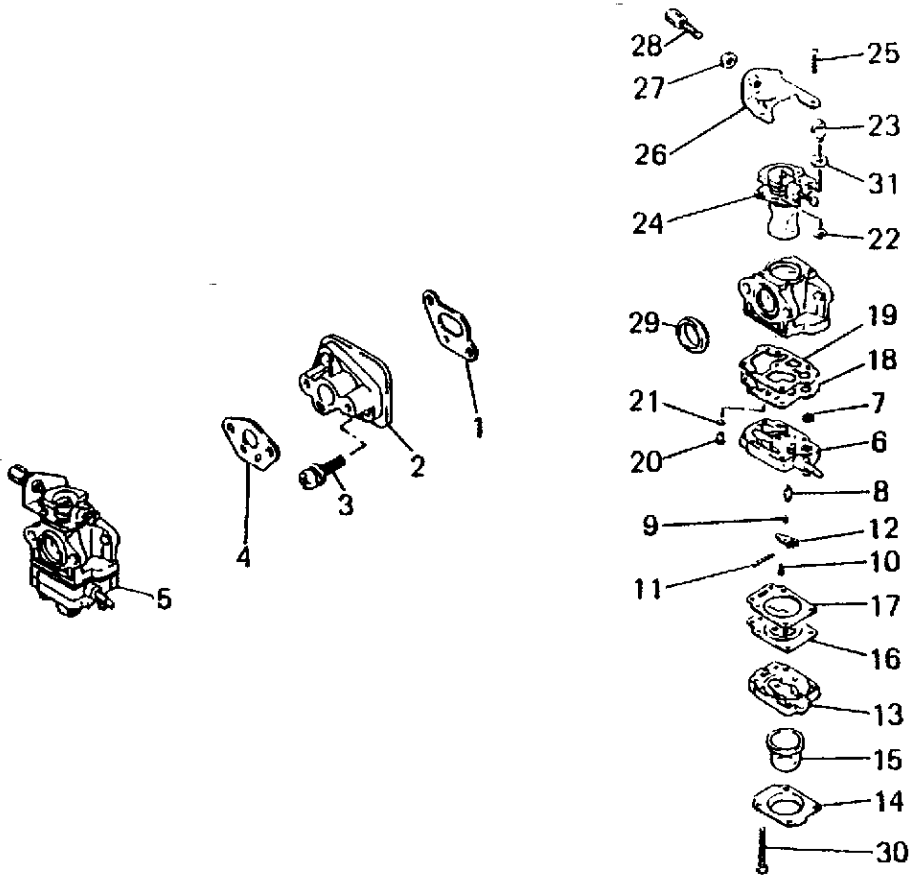

Nr.	Cod.	Q.ty	Descrizione	Description	Description	Beschreibung
1	MKW34042AA	1	Guarnizione	Gasket	Joint	Dichtung
2	MKK31018AA	1	Isolatore	Insulator	Isolateur	Isolator
3	MFR64960A	2	Vite	Screw	Vis	Schraube
4	MKW39050AA	1	Guarnizione	Gasket	Joint	Dichtscheibe
5	MKK22010AA	1	Carburatore (incl.6-31)	Carburetor (incl.6-31)	Carburateur(incl. 6-31)	Vergaser (incl.6-31)
6	MKK22016AA002	1	Corpo pompa (incl.7-12)	Body, pump (incl. 7-12)	Corps de pompe (incl. 7-12)	Körper(incl. 7-12)
7	MKK21009AA002	1	Filtro	Screen	Filtre	Filter
8	MKK22007AA003	1	Spillo	Valve, needle	Pointeau	Nadelventil
9	MKK23002AA005	1	Molla	Spring	Ressort	Feder
10	MKK22007AA005	1	Vite	Screw	Vis	Schraube
11	MFR66652XX027	1	Spina	Pin	Goupille	Bolzen
12	MFR66652XX029	1	Leva	Lever	Levier	Hebel
13	MKK22007AA006	1	Corpo	Body	Corps	Körper
14	MKK22007AA007	1	Coperchio	Cover	Couvercle	Deckel
15	MKK21017AA013	1	Primer	Primer pump	Pompe carburation	Pumpe
16	MFR66652XX013	1	Membrana	Diaphragm	Membrane	Membran
17	MKK22007AA012	1	Guarnizione	Gasket	Joint	Dichtscheibe
18	MKK21017AA005	1	Membrana	Diaphragm	Membrane	Membran
19	MKK21017AA004	1	Guarnizione	Gasket	Joint	Dichtscheibe
20	MKK22002AA003	1	Getto principale	Jet, main	Jet principal	Vergaser-düse
21	MKK21017AA002	11	O-ring	O-ring	Joint torique	O-ring
22	MFR66652XX032	1	Fermo	Clip	Collier	Halter
23	MKK21024AA022	1	Ferma cavo	Holder, wire	Collier	Kabelhalter
24	MKK22008CA112	1	Valvola	Valve, throttle	Vanne à papillon	Klappe
25	MKK21017AA021	2	Vite	Screw	Vis	Schraube
26	MKK22023AA014	1	Supporto	Bracket	Support	Lager
27	MKK21017AA027	1	Dado	Nut	Écrou	Mutter
28	MKK21017AA126	1	Vite	Screw	Vis	Schraube
29	MKK21024AA014	1	Anello	Packing	Bague	Ring
30	MKK22007AA019	4	Vite	Screw	Vis	Schraube
31	MKK22024EA024	1	Ranella	Washer	Vis	Schraube

- 6 - FILTRO ARIA
- 6 - AIR CLEANER SYSTEM
- 6 - FILTRE À AIR
- 6 - LUFTFILTER

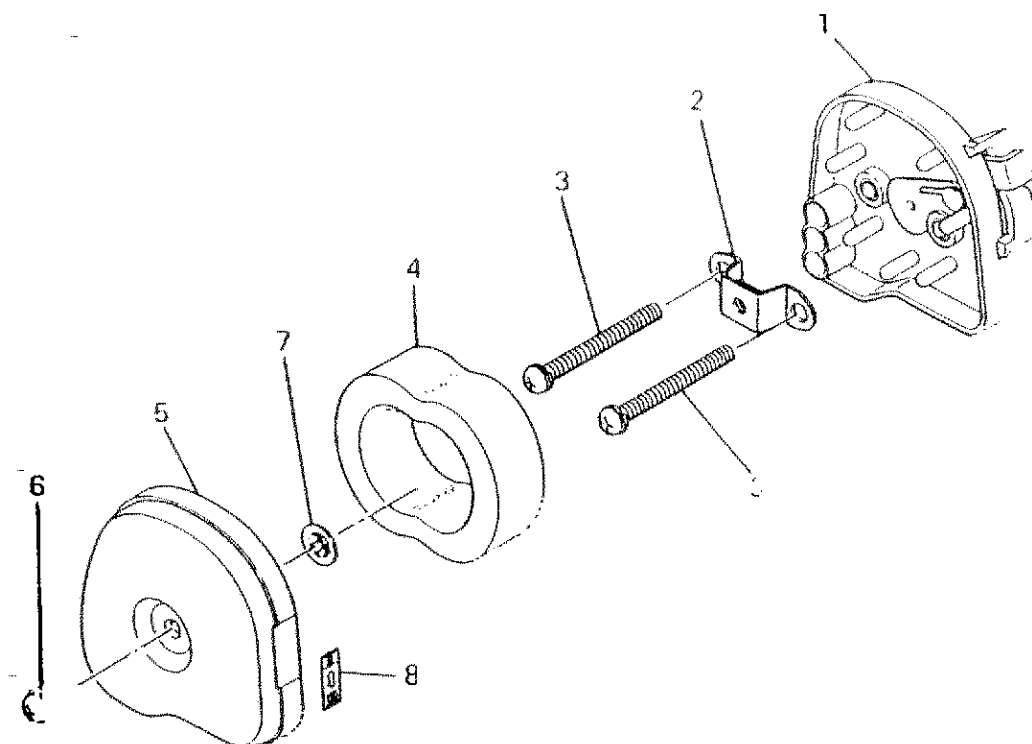

Nr.	Cod.	Q.ty	Descrizione	Description	Description	Beschreibung
1	MKA01053AA		Filtro aria	Air cleaner	Filtre à air	Luffilter
2	MKA90064AA		Supporto	Bracket	Support	Lager
3	MH081D05X050	2	Vite	Screw	Vis	Schraube
4	MKA40045AA	1	Elemento filtro	Element, cleaner	Filtre	Filtereinsatz
5	MKA20032AA	1	Coperchio filtro	Cover, cleaner	Couvercle	Deckel
6	MH071D05X012K	1	Vite	Screw	Vis	Schraube
7	MN611K05	1	Dado	Nut	Écrou	Mutter
	MFR67555	1	Decalcomania	Label, name	Autocollant	Aufkleber

- 7 - MARMITTA
- 7 - MUFFLER SYSTEM
- 7 - BOÎTE D'ÉCHAPPEMENT
- 7 - SCHALLDÄMPFER

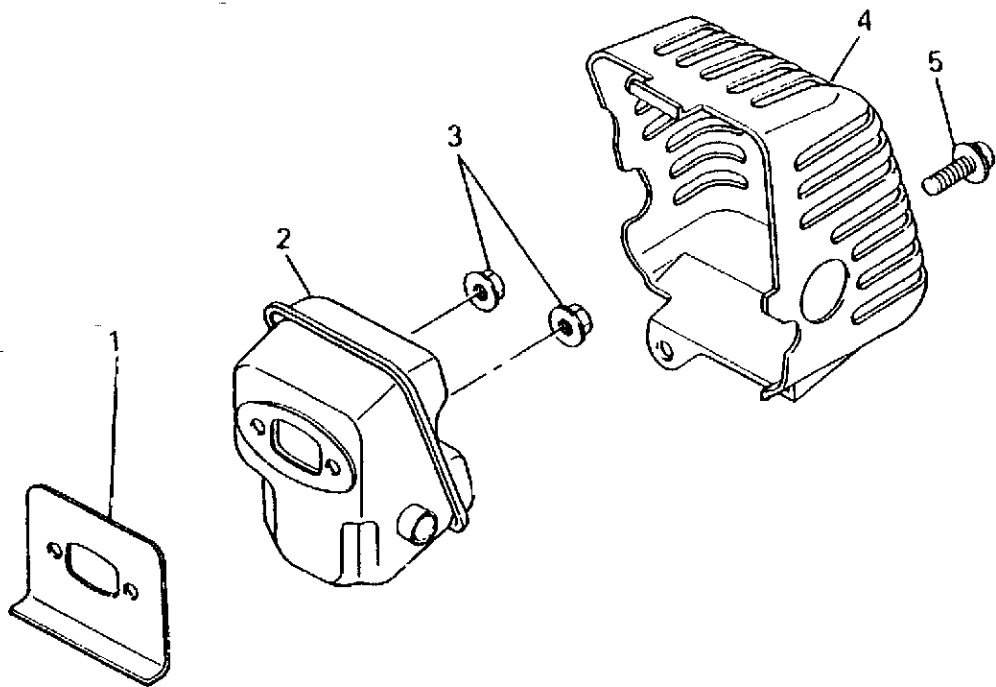

Nr.	Cod.	Q.ty	Descrizione	Description	Description	Beschreibung
1	MKM70024AA	1	Guarnizione	Gasket, muffler	Joint	Dichtscheibe
2	MKM01035AA	1	Marmitta	Muffler	Boîte d'échappement	Schalldämpfer
3	MFR67566	2	Dado	Nut, flange	Écrou	Mutter
4	MKM21004AA	1	Coperchio marmitta	Cover, muffler	Couvercle	Deckel
5	MKU12018BA	1	Vite	Screw	Vis	Schraube

- 8 - FRIZIONE
- 8 - CLUTCH SYSTEM
- 8 - EMBRAYAGE
- 8 - KUPPLUNG

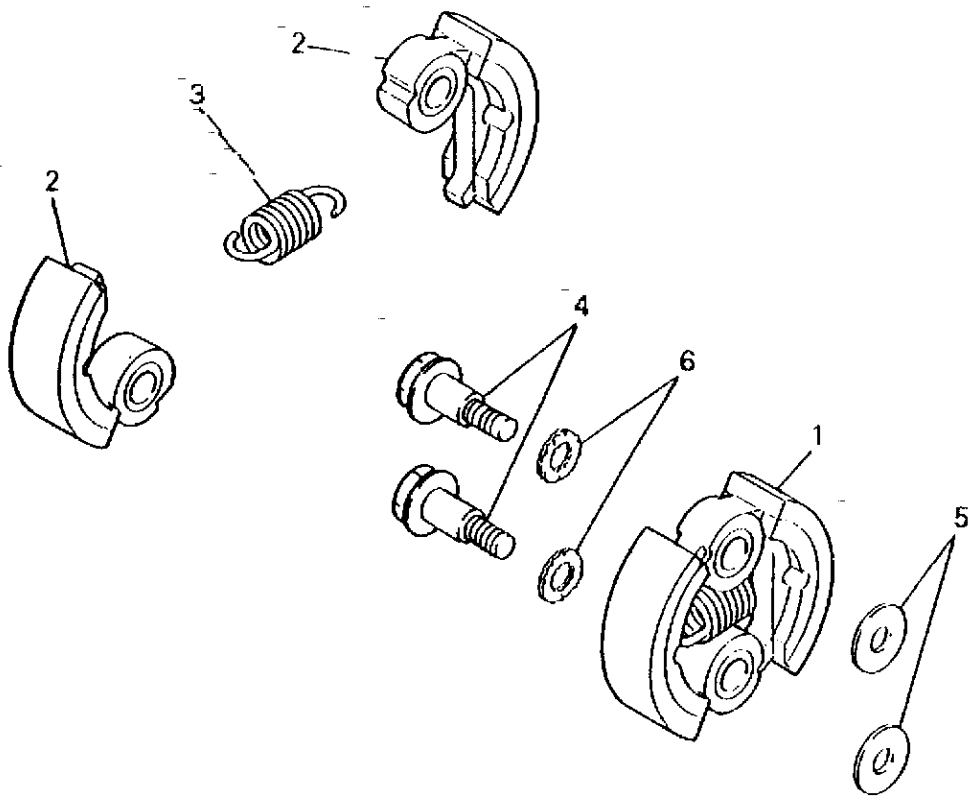

Nr.	Cod.	Q.ty	Descrizione	Description	Description	Beschreibung
1	MKT01003AA	1	Frizione (incl. 2-3)	Clutch (incl. 2-3)	Embrayage (incl. 2-3)	Kupplung (incl. 2-3)
2	MKT12005AA	2	Scarpa frizione	Shoe, clutch	Mâchoire d'embrayage	Kupplung
3	MFR64233A	1	Molla	Spring	Ressort	Feder
4	MKT14002AA	2	Bullone frizione	Bolt, clutch	Boulon	Schraube
5	MFR67347A	2	Ranella	Washer	Rondelle	Unterlegscheibe
6	MKU36001DA	2	Ranella	Washer	Rondelle	Unterlegscheibe

- 9 - AVVIAMENTO
- 9 - RECOIL STARTER SYSTEM
- 9 - DÉMARREUR À MAIN
- 9 - ANLASSEN VON HAND

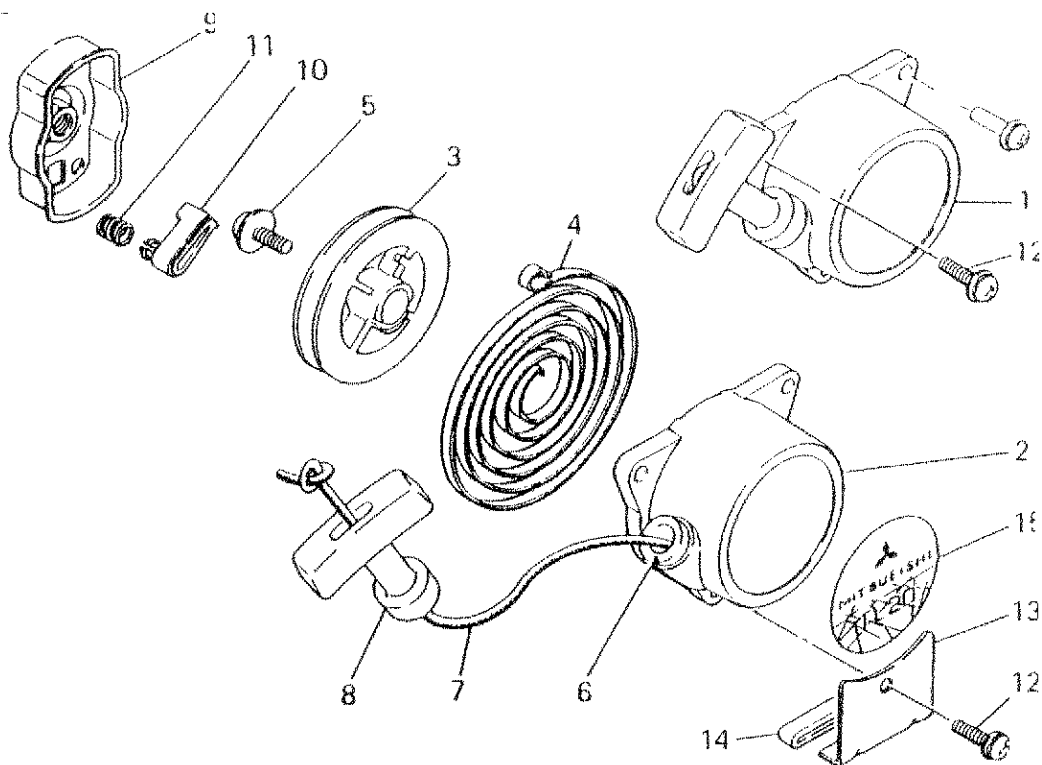

Nr.	Cod.	Q.ty	Descrizione	Description	Description	Beschreibung
1	MKS20055AA	1	Avviamento (incl.2-8)	Recoil starter (incl.2-8)	Démarreur à main (incl.2-8)	Anlassen von Hand (incl. 2-8)
2	MKS20055AA001	1	Carter avviamento	Case, starter	Boîtier	Gehäuse
3	MFR67166XX002	1	Puleggia	Reel	Poulie	Riemenscheibe
4	MFR67166XX003	1	Molla	Spring	Ressort	Feder
5	MKS20055AA004	1	Vite	Screw	Vis	Schraube
6	MKS20055AA005	1	Guida corda	Guide	Guide	Fuehrung
7	MFR67166XX007	1	Corda avviamento	Rope, starter	Corde lanceur	Schnur
8	MKS20055AA008	1	Manopola	Knob, starter	Poignée	Griff
9	MKS03001AA	1	Innesto (incl.10,11)	Cover (incl.10,11)	Couvercle (incl.10,11)	Deckel (incl.10,11)
10	MKS03001AA002	1	Saltarello	Ratchet	Crochet	Sperrnocken
11	MKS03001AA103	1	Molla	Spring, return	Ressort	Feder
12	MKU12018BA	2	Vite	Screw	Vis	Schraube
13	MKF09016AA	1	Supporto (incl. 14)	Bracket (incl. 14)	Support (incl. 14)	Platte (incl. 14)
14	MKF80004AA	1	Gommino	Rubber spacer	Épaisseur en caoutchouc	Büchse

10 - SERBATOIO
 10 - FUEL TANK SYSTEM
 10 - RÉSERVOIR
 10 - TANK

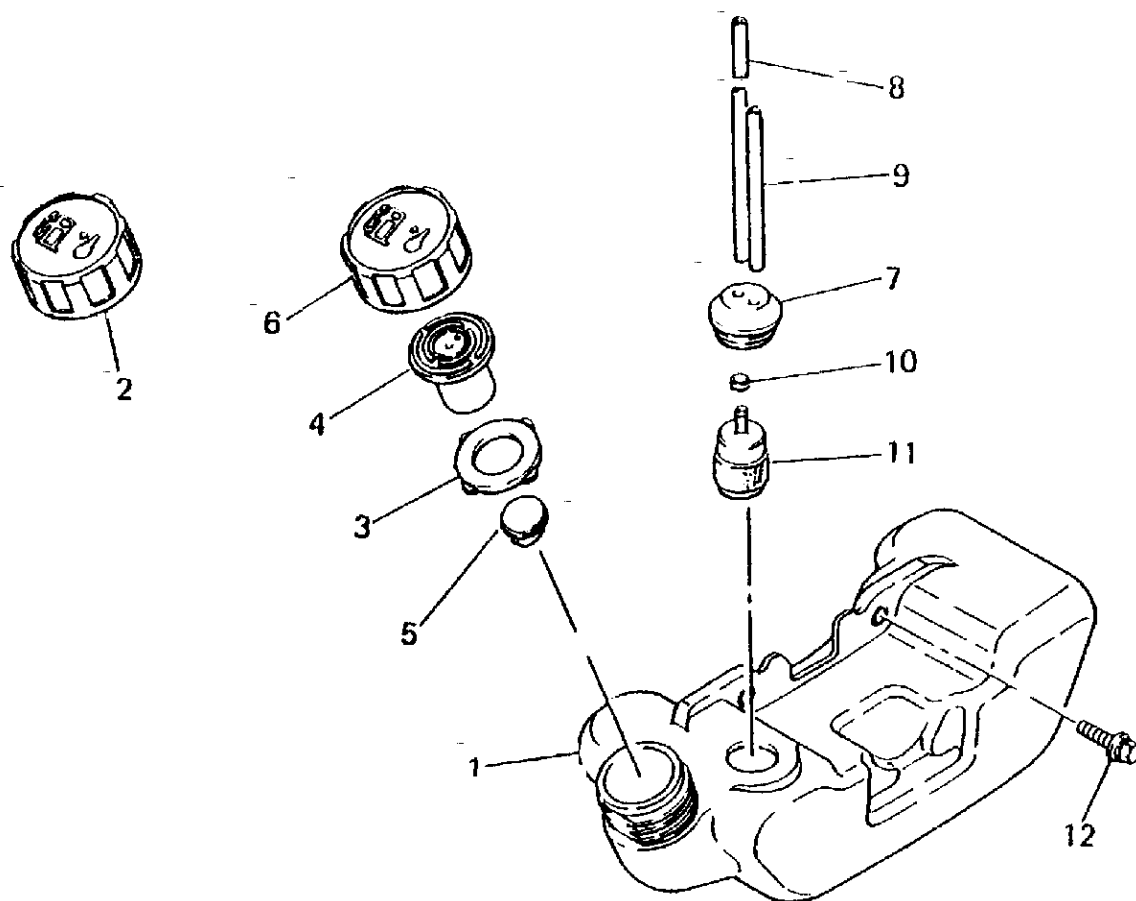

Nr.	Cod.	Q.ty	Descrizione	Description	Description	Beschreibung
1	MKF01056AA	1	Serbatoio (incl. 2-11)	Tank assy (incl. 2-11)	Réservoir (incl. 2-11)	Tank (incl. 2-11)
2	MKF05014AA	1	Tappo (incl. 3-6)	Cap assy (incl. 3-6)	Bouchon (incl. 3-6)	Tankverschluss (incl. 3-6)
3	MKF90049AA	1	Paraolio	Packing	Joint	Dichtscheibe
4	MKF09011AA	1	Valvola sfiato	Valve, breather	Soupape	Ventil
5	MKF90050AB	1	Tappo	Cap	Bouchon	Stopfen
6	MKF21012AA	1	Tappo serbatoio	Cap, fuel tank	Bouchon du réservoir	Tankverschluss
7	MKF90048AA	1	Tappo	Plug	Bouchon	Gummistopfen
8	MKF70011CA	1	Tubo miscela	Tube, fuel	Tube carburant	Brennstoffleitung
9	MFR64255F	1	Tubo miscela	Tube, fuel	Tube carburant	Brennstoffleitung
10	MKF01033AA007	1	Bussola	Bushing	Bague	Buchse
11	MKF40004AA	1	Filtro carburante	Filter, fuel	Filtre carburant	Filter
12	MKU12016AA	2	Bullone	Bolt	Boulon	Schraube

11 - CARTER FRIZIONE
 11 - CLUTCH CASE
 11 - BOÎTIER D'EMBRAYAGE
 11 - KUPPLUNG KASTEN

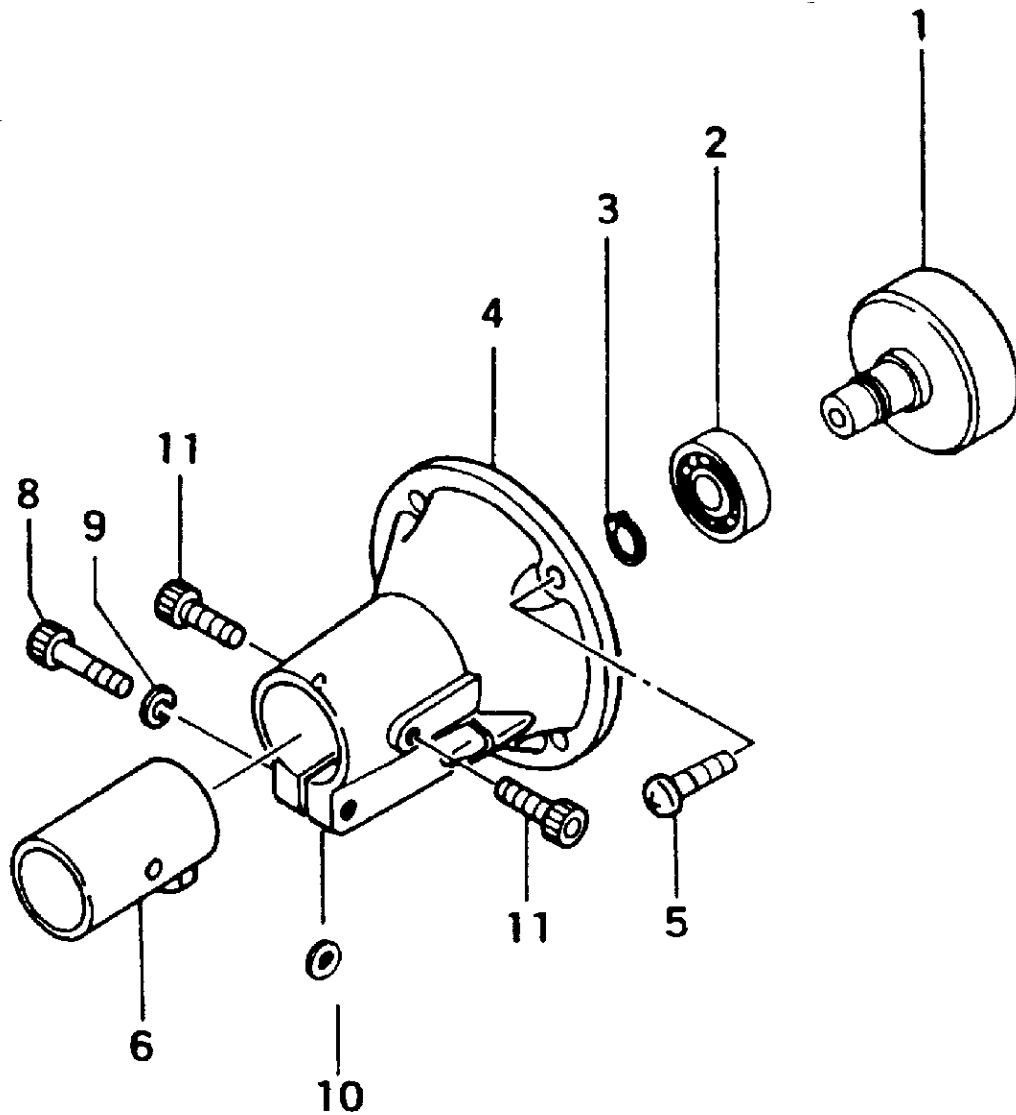

Nr.	Cod.	Q.ty	Descrizione	Description	Description	Beschreibung
1	P3060107BR	1	Campana frizione	Clutch, drum	Entraîneur	Trommel
2	P999-61600-102	2	Cuscinetto	Bearing	Roulement	Lager
3	1070001A1	1	Seeger	Stop ring	Seeger	Seeger
4	P3050079GR	1	Carter frizione	Clutch, case	Boîtier d'embrayage	Kupplung kasten
5	P1010261	4	Vite	Screw	Vis	Schraube
6	P599-0636J-210	1	Antivibrante	Cushion rubber	Amortiseur	Schwingungsdämpfer
8	P990-51050-253	1	Bullone	Bolt	Boulon	Schraube
9	P1020056	1	Rondella	Washer	Rondelle	Unterlegscheibe
10	P992-01050-061	1	Spessore	Washer	Épaisseur	Beilagerring
11	P1010121	2	Bullone	Bolt	Boulon	Schraube
12	1020008A1	4	Vite	Screw	Vis	Schraube

- 12 - ASTA CON IMPUGNATURA SINGOLA
- 12 - SHAFT WITH SINGLE HANDLE
- 12 - ARBRE DE TRANSMISSION AVEC PORTAGE ANNEAU
- 12 - ANTRIEBSWELLE + EINFACHGRIFF

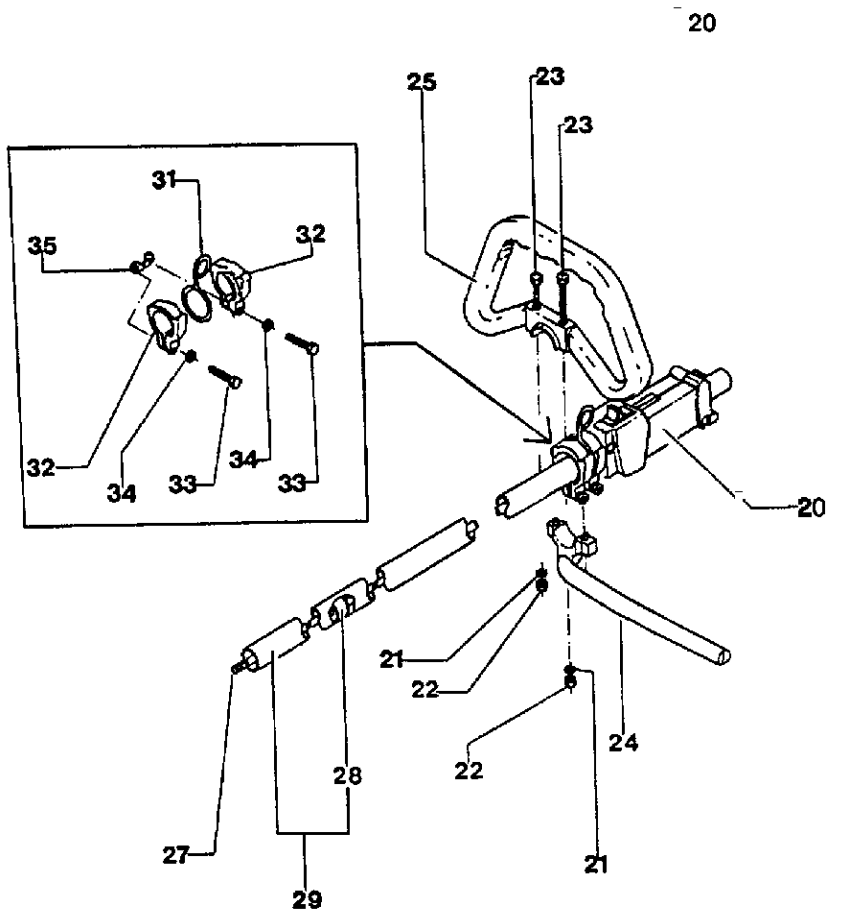
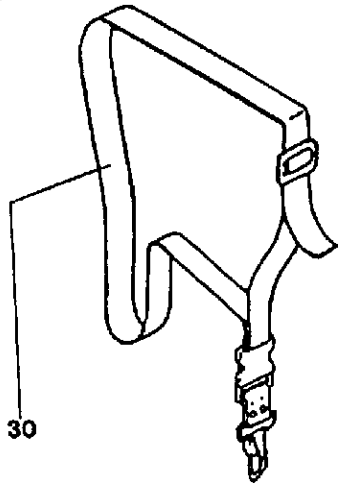
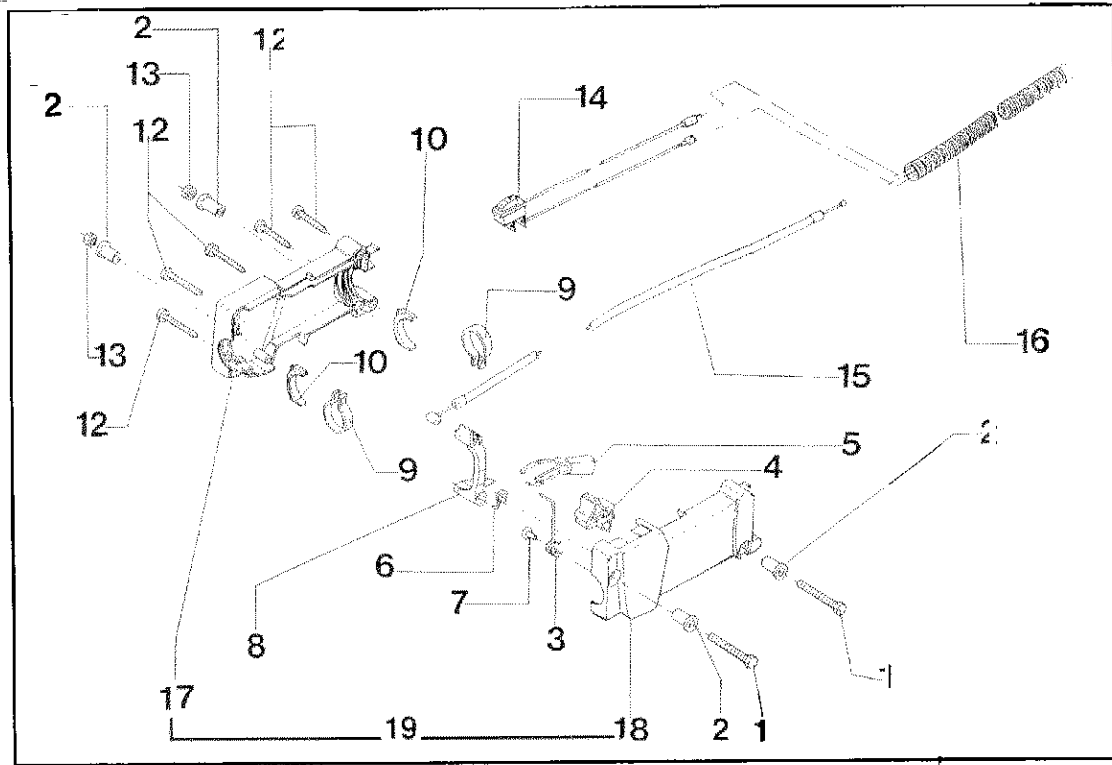

Nr.	Cod.	Q.ty	Descrizione	Description	Description	Beschreibung
1	1010002A1	2	Vite	Screw	Vis	Schraube
2	P3040320ZT	4	Bussola	Bushing	Douille	Büchse
3	P3020037ZT		Molla per pulsante	Spring	Ressort	Feder
4	P2020406R	1	Pulsante 1/2 gas	Half-throttle button	Bouton de demi-gaz	Schlossdrucktaster
5	P2020388R	1	Leva di bloccaggio	Stop lever	Levier	Hebel
6	P3020036ZT	1	Molla	Spring	Ressort	Feder
7	P1020109		Ribattino	Rivet	Rivet	Niet
8	P2020409R		Leva acceleratore	Throttle lever	Levier de l'accélérateur	Gashebel
9	P4010244ZT	2	Fascetta	Clamp	Collier	Rapband
10	P2020384	4	Riduzione	Reduction	Réduction	Reduktion
12	P1010216	5	Vite	Screw	Vis	Schraube
13	1050002A1	2	Dado	Nut	Écrou	Mutter
14	P5080038		Interruttore completo	Switch assy	Interrupteur complet	Steuerung
15	P5020075		Cavo acceleratore	Throttle wire	Câble de l'accélérateur	Gaskabel
16	P164-10016-80	mt. 0,19	Guaina	Protection tube	Protection	Schutz
17			Vedi Nr 19	See Nr. 19	Voir Nr. 19	Siehe Nr. 19
18			Vedi Nr 19	See Nr. 19	Voir Nr. 19	Siehe Nr. 19
19	P2020417	1	Impugnatura	Handle	Portage	Steuerung
20	P3080045	1	Impugnatura compl.	Handle assy	Portage comp.	Steuerung Komp.
21	1020013A1	2	Rondella	Washer	Rondelle	Unterlegscheibe
22	1050003A1	2	Dado	Nut	Écrou	Mutter
23	P1010226	2	Vite	Screw	Vis	Schraube
24	P2020397		Asta di protezione	Protection shaft	Tige de protection	Stange
25	P500-37300-20	1	Manico asta	Single handle	Portage anneau	Griff
27	P343-37618-200	1	Albero trasmissione	Drive shaft	Arbre de transmission	Antriebswelle
28	P2090015	5	Gommino	Bushing	Douille	Büchse
29	P2090010		Asta con gommino	Drive shaft	Arbre de transmission	Antriebswelle
30	P5110023		Bretelle	Harness	Bandoulière	Schultergurt
31	P335-37307-20		Supporto bretelle	Suspension hook	Métal de levage	Haltearm
32	P334-37304-210	2	Fermo supporto	Lifting metal collar	Collier de levage	Sperrung
33	P990-51050-303	2	Vite	Screw	Vis	Schraube
34	P992-01050-061	2	Rondella	Washer	Rondelle	Unterlegscheibe
35	P315-37304-20		Piastrina	Plate	Plaque	Platte

- 13 - COPPIA CONICA
- 13 - GEAR CASE
- 13 - CARTER D'ENGRENAGE
- 13 - KEGELRADERPAARUNG

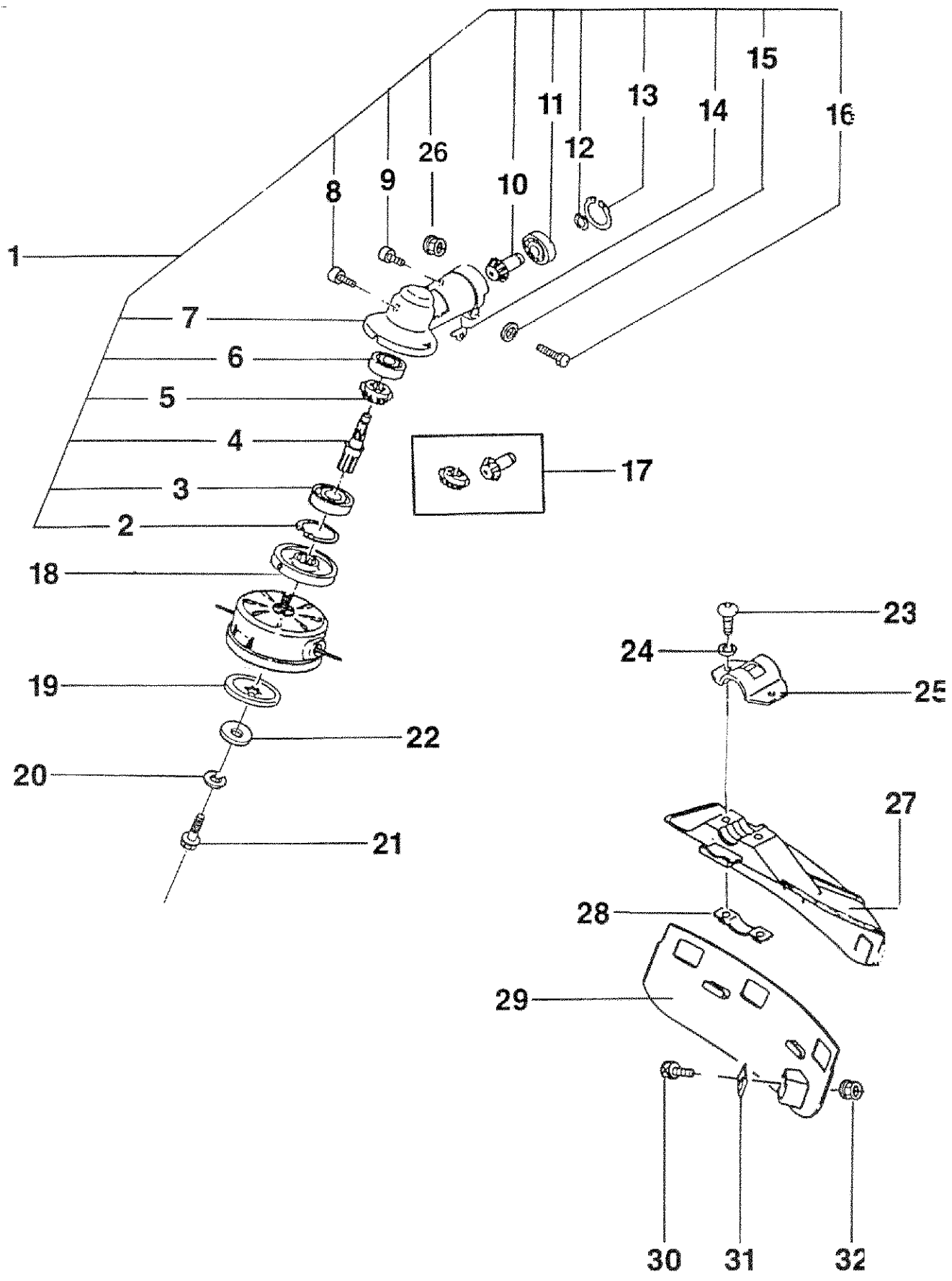

Nr.	Cod.	Q.ty	Descrizione	Description	Description	Beschreibung
1	P2090017	1	Scatola completa	Gear case assy	Carter d'engrenage comp.	Kegeltrieb komp.
2	P1070004	1	Seeger	Stop ring	Seeger	Seeger
3	P999-61600-104	1	Cuscinetto	Bearing	Roulement	Lager
4	P304-33983-200	1	Alberino	Shaft	Arbre	Welle
5			Vedi Nr. 17	See Nr. 17	Voir Nr. 17	Siehe Nr. 17
6	P999-61626-000	1	Cuscinetto	Bearing	Roulement	Lager
7	P300-33983-20GR	1	Carter testina	Gear case	Carter d'engrenage	Kasten
8	P990-23060-081	1	Vite	Screw	Vis	Schraube
9	P990-51050-103	1	Vite	Screw	Vis	Schraube
10			Vedi nr. 17	See Nr. 17	Voir Nr. 17	Siehe Nr. 17
11	P999-61609-002	1	Cuscinetto	Bearing	Roulement	Lager
12	P993-50009-002	1	Seeger	Stop ring	Seeger	Seeger
13	P993-51024-002	1	Seeger	Stop ring	Seeger	Seeger
14	P992-01050-061	1	Rondella	Washer	Rondelle	Unterlegscheibe
15	P1020056	1	Rondella	Washer	Rondelle	Unterlegscheibe
16	P1010236	1	Vite	Screw	Vis	Schraube
17	P2090016	1	Coppia conica	Gear assy	Couple conique	Kegelraderpaarung
18	P310-33983-200	1	Supporto sup. lama	Cutter holder	Support de lame	Halter
19	P311-33983-200	1	Supporto inf. lama	Cutter holder	Support de lame	Halter
20	P992-10080-012	1	Rondella	Washer	Rondelle	Unterlegscheibe
21	P312-37623-20	1	Vite lama	Blade screw	Boulon de lame	Messerschraube
22	1020014A1	1	Rondella	Washer	Rondelle	Unterlegscheibe
23	P1010264	2	Vite	Screw	Vis	Schraube
24	1020008A1	1	Rondella	Washer	Rondelle	Unterlegscheibe
25	P4010247ZT	1	Supporto inferiore	Lower bracket	Support inférieur	Halter
26	1050002A1	2	Dado	Nut	Écrou	Mutter
27	P2020402NE	1	Protezione superiore	Safety guard	Couvercle de sécurité	Schutz
28	P445-37380-20	1	Supporto inferiore	Lower bracket	Support inférieur	Lager
29	P2020404NE	1	Protezione inferiore	Safety guard	Couvercle de sécurité	Schutz
30	P994-14050-121	1	Vite	Screw	Vis	Schraube
31	P4010353BR	1	Coltello taglia filo	Wire cutter	Lame de coupage	Schneide
32	1050002A1	1	Dado	Nut	Écrou	Mutter

- 1 - GRUPPO CASSA
- 1 - CRANKCASE SYSTEM
- 1 - BOÏTIER
- 1 - GEHÄUSE

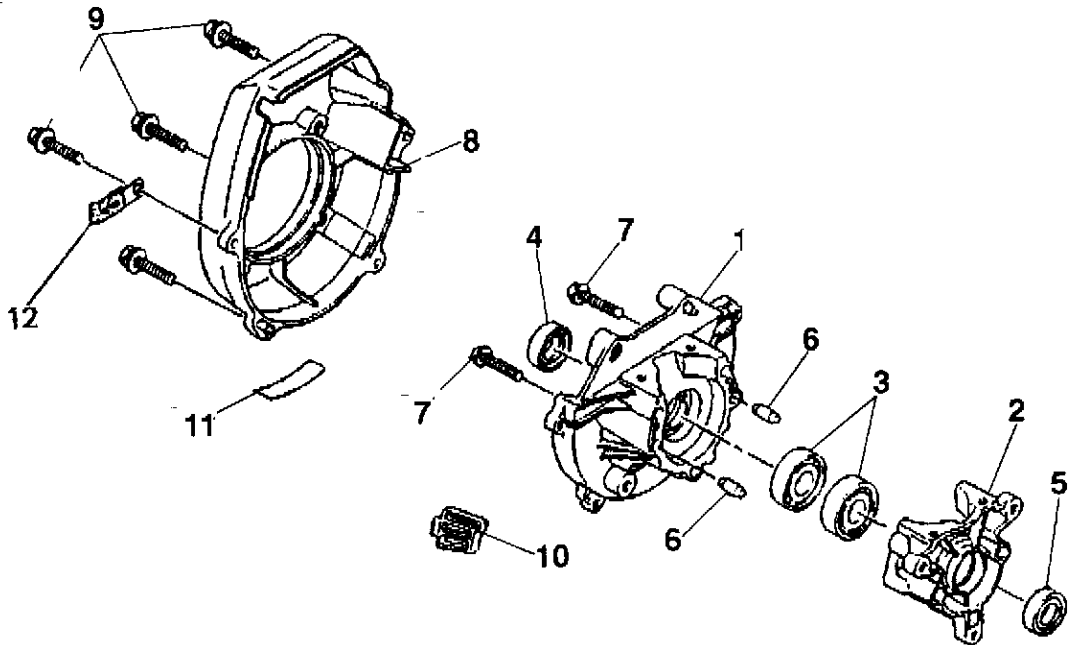

Nr.	Cod.	Q.ty	Descrizione	Description	Description	Beschreibung
1	MKB12010AA	1	Carter motore	Case, drive	Boîtier	Gehäuse
2	MKB12011AA	1	Cassa motore	Case, starter	Boîtier	Gehäuse
3	MS110X60X000	2	Cuscinetto a sfera	Bearing, ball	Roulement	Lager
4	MFR66628	1	Paraolio	Seal, oil	Joint torique	Dichtring
5	MKW21006AA	1	Paraolio	Seal, oil	Joint torique	Dichtring
6	MKU40003AA	2	Spina	Pin, dowel	Goupille	Bolzen
7	MH081D05X025	3	Vite	Screw	Vis	Schraube
8	MKH30015BA	1	Carter motore	Case, fan	Boîtier	Gehäuse
9	MKU12019AA	4	Bullone	Bolt	Boulon	Schraube
10	MKH90023AA	1	Coperchio	Cover	Couvercle	Deckel
11	MKW56056AA	1	Decalcomania	Label	Autocollant	Aufkleber
12	MKU60001AA	1	Fermo	Clamp	Collier	Rapband