

94-6775
323-0500

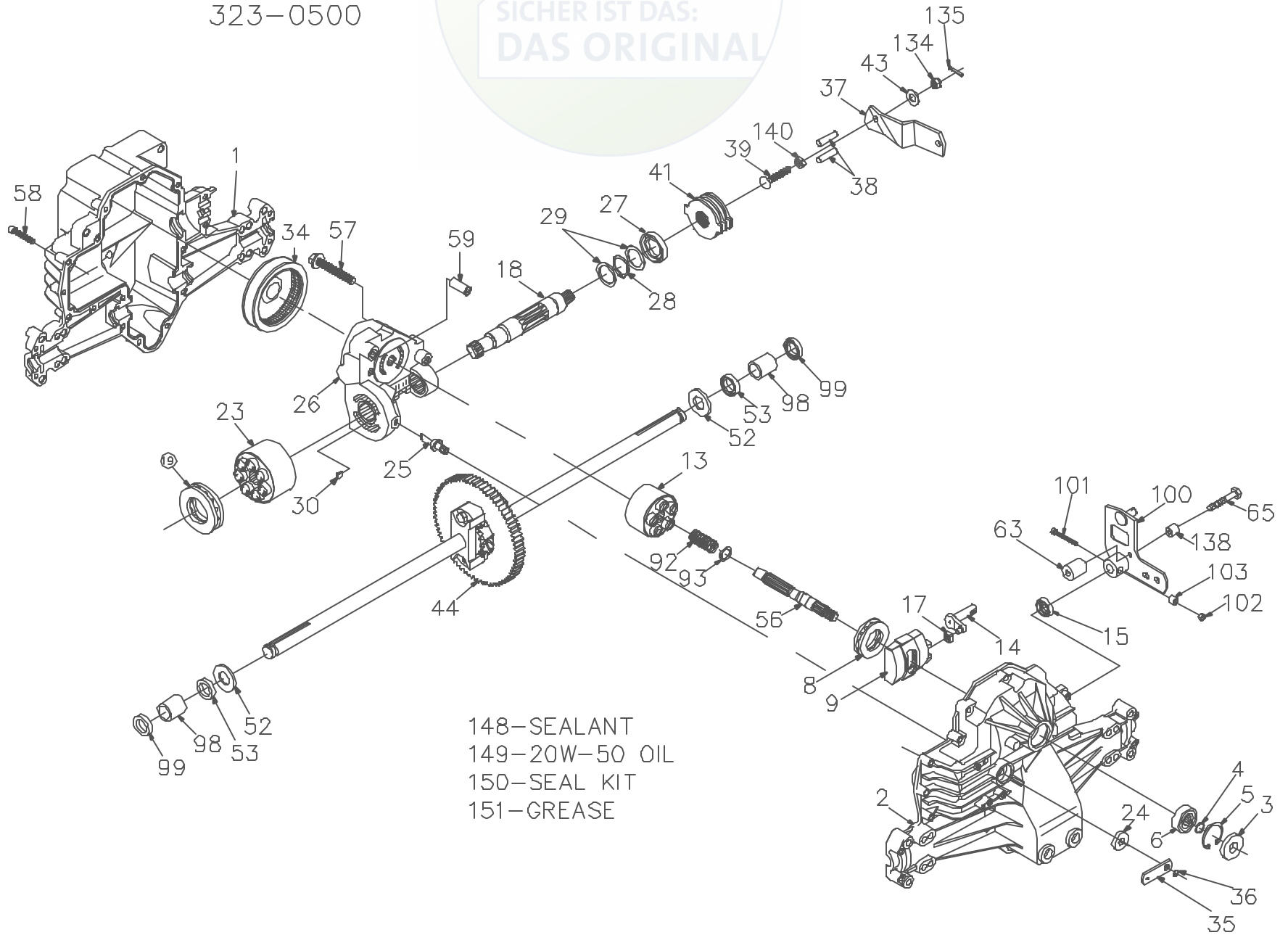

148-SEALANT
149-20W-50 OIL
150-SEAL KIT
151-GREASE

94-6775
323-0500

ITEM NO	HYDRO-GEAR PART NO	QTY	DESCRIPTION
1	44863RM	1	HOUSING, LOWER
2	70254	1	ASSEMBLY, UPPER HOUSING
		1	UPPER HOUSING
		1	TRUNNION JOURNAL BEARING
3	9008000-0128	1	SEAL-LIP
4	2003016	1	RING-WIRE RETAINING
5	2003052	1	RING-RETAINING
6	2003043	1	BEARING-SHAFT BALL
8	50551	1	BEARING-THRUST 30X52X13
9	2003087	1	SWASHPLATE-VARIABLE
13	70331	1	BLOCK-CYLINDER ASS'Y.
		1	BLOCK-CYLINDER
		5	PISTON
		5	PISTON SPRING
		5	PISTON SPRING WASHER
14	2003005	1	ARM-TRUNNION
15	9008000-0126	1	SEAL-LIP
17	2000015	1	GUIDE-SLOT
18	50449	1	SHAFT-MOTOR
19	50552	1	BEARING-THRUST 42X68X16
23	70082	1	BLOCK-CYLINDER ASS'Y.
		1	BLOCK-CYLINDER
		7	PISTON
		7	PISTON SPRING
		7	PISTON SPRING WASHER
24	45074	1	SEAL-LIP 10X25X7
25	2003555	1	ACTUATOR-BYPASS
26	70250	1	CENTERSECTION ASSEMBLY KIT
		1	BYPASS PLATE
		2	CHECK PLUG ASSEMBLY
		1	CENTERSECTION
		1	DU BEARING
		3	BOLT, 3/8-24 X 2.5
		1	BUSHING
27	45075	1	SEAL-LIP 26X42X8
28	50007	1	RING-RETAINING
29	44872	2	WASHER-26X35X1
30	2003554	1	BYPASS PLATE
34	44964	1	OIL FILTER ELEMENT
35	44866	1	ARM-BYPASS

ITEM NO	HYDRO-GEAR PART NO	QTY	DESCRIPTION
36	44870	1	RING-RETAINING
37	50131	1	ARM-ACTUATING
38	44891	2	PIN-ACTUATING
39	50316	1	BOLT-5/16-24 X 1-3/4
41	70135	1	BRAKE ROTOR/STATOR KIT
		4	BRAKE STATOR
		2	BRAKE ROTOR
43	44130	1	WASHER-7/16 X 7/8 X .060
44	70126	1	DIFFERENTIAL ASSEMBLY
		2	AXLE SHAFT
		1	72T DIFFERENTIAL GEAR
		2	DIFFERENTIAL HOUSING
		2	14T BEVEL GEAR
		2	10T PLANET GEAR
		2	RETAINING RING
		2	DIFFERENTIAL LOCKING BOLT
		1	DIFFERENTIAL SPACER
52	44875	2	WASHER-3/4 X 1.5 X .13
53	45076	2	SEAL-.75 X 1.25 X .250
56	2003021	1	SHAFT-INPUT
57	50016	3	BOLT, 3/8-24 X 2.5
58	44878	20	BOLT- 1/4-20 X 1.38
59	50002	2	PIN-.5 OD X .43 ID X .750
63	50156	1	SPACER
65	44123	1	BOLT, 1/4-20 X 2
92	2003014	1	SPRING, BLOCK
93	2003017	1	WASHER, BLOCK THRUST
98	50137	2	SLEEVE BEARING
99	50941	2	SEAL, LIP 0.75X1.00X0.158
100	50294	1	CONTROL ARM ASSEMBLY
101	50140	1	SOCKET HEAD CAP SCREW
102	50141	1	NUT, 10-24
103	50142	1	SPACER
134	44142	1	CASTLE NUT, 5/16-18
135	44101	1	COTTER PIN
138	23770	1	SPACER
140	50269	1	NUT, HEX 5/16-24
148	50928	1	SEALANT
149		77oz	20W-50 OIL
150	70312	1	SEAL KIT
151	50416	1	GREASE