

718-0255
313-0750

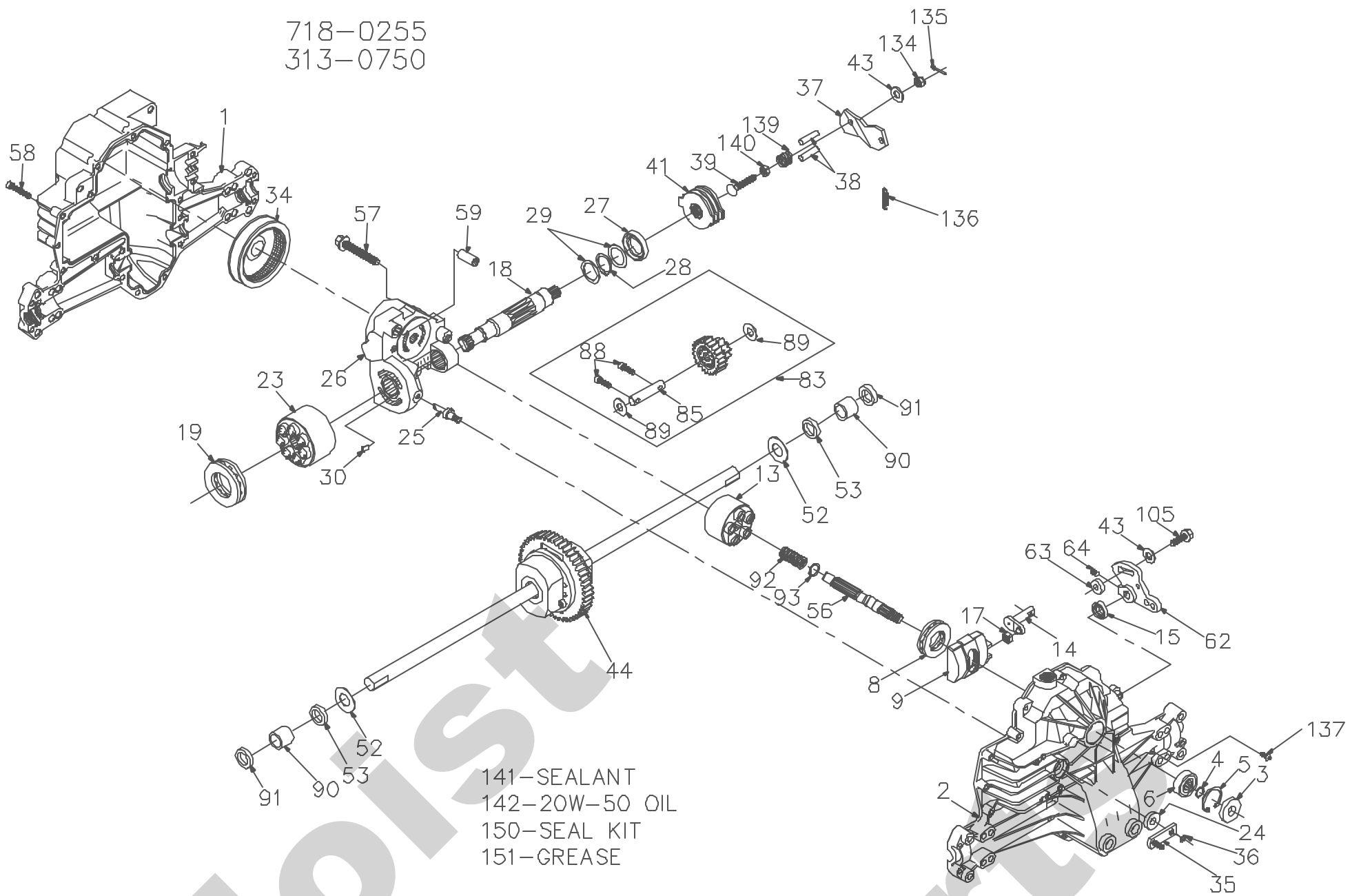

718-0255
313-0750

ITEM NO	HYDRO-GEAR PART NO	QTY	DESCRIPTION	ITEM NO	HYDRO-GEAR PART NO	QTY	DESCRIPTION
1	50074RM	1	HOUSING, LOWER	41	70135	1	BRAKE ROTOR/STATOR KIT
2	70255	1	ASSEMBLY, UPPER HOUSING	4		4	STATOR-BRAKE
		1	HOUSING, UPPER	2		2	ROTOR-BRAKE
		1	BEARING-TRUNNION JOURNAL	43	44130	2	WASHER-7/16 X 7/8 X .060
3	9008000-012B	1	SEAL-LIP	44	70131	1	DIFFERENTIAL ASSEMBLY
4	2003016	1	RING-WIRE RETAINING			1	GEAR-DIFF. 50T
5	2003052	1	RING-RETAINING			2	DIFF. COVER
6	2003043	1	BEARING-SHAFT BALL			2	GEAR-BEVEL 15T
8	50551	1	BEARING-THRUST 30X52X13			2	GEAR-PLANET 15T
9	2003087	1	SWASHPLATE-VARIABLE			2	JAM NUT
13	70331	1	BLOCK-CYLINDER ASS'Y.			4	BOLT- 1/4-20 X 1.38
		1	BLOCK-CYLINDER			1	AXLE SHAFT, RH
		5	PISTON			1	AXLE SHAFT, LH
		5	PISTON SPRING			2	BEARING, BLOCK
		5	PISTON SPRING WASHER			1	SHAFT
14	2003005	1	ARM-TRUNNION	52	50152	2	WASHER-3/4 X 1.5 X .03
15	9008000-012B	1	SEAL-LIP	53	45076	2	SEAL-.75 X 1.25 X .250
17	2000015	1	GUIDE-SLOT	56	50005	1	SHAFT-INPUT
18	50449	1	SHAFT-MOTOR	57	50016	3	BOLT, 3/8-24 X 2.5
19	50552	1	BEARING-THRUST 42X68X16	58	44876	21	BOLT- 1/4-20 X 1.38
23	70082	1	BLOCK-CYLINDER (MOTOR) ASSY	59	50002	2	PIN-.5 OD X .43 ID X .750
		1	BLOCK-CYLINDER	62	45007	1	ARM-CONTROL
		7	PISTON	63	50034	1	PUCK-DAMPENER
		7	PISTON SPRING	64	50018	1	SET SCREW
		7	PISTON SPRING WASHER	83	70292	1	JACK SHAFT/PINION GEAR ASSEMBLY
24	45074	1	SEAL-LIP 10X25X7			1	JACK SHAFT
25	2003555	1	ACTUATOR-BYPASS			1	17T-23T CLUSTER ASSEMBLY
26	70250	1	CENTERSECTION ASSEMBLY			2	CAPSCREW 6M X 20 LG
		1	PLATE-BYPASS			2	WASHER 7/16 X 1 X .5
		2	CHECK PLUG ASSEMBLY			1	JACK SHAFT
		1	CENTER SECTION	85	50559	1	JACK SHAFT
		1	DU BEARING	88	50154	2	CAPSCREW 6M X 20 LG
		3	BOLT-3/8-24 X 2.5	89	50132	2	WASHER 7/16 X 1 X .5
		1	BUSHING	90	50118	2	SLEEVE BEARING
27	45075	1	SEAL-LIP 26X42X8	91	50941	2	SEAL, LIP 0.75X1.00X0.158
28	50007	1	RING-RETAINING	92	2003014	1	SPRING, BLOCK
29	44872	2	WASHER-26X35X1	93	2003017	1	WASHER, BLOCK THRUST
30	2003554	1	BYPASS PLATE	105	50282	1	FLANGE HEAD SCREW, 5/16-24 X 1
34	44964	1	OIL FILTER ELEMENT	134	44142	1	CASTLE NUT, 5/16-24
35	50126	1	ARM-BYPASS	135	44101	1	COTTER PIN
36	44870	1	RING-RETAINING	136	50384	1	EXTENSION SPRING
37	50130	1	ARM-ACTUATING	137	50653	1	SCREW, 10-32 X 1/2
38	44891	2	PIN-ACTUATING	139	50431	1	COMPRESSION SPRING
39	50316	1	BOLT-5/16-18 X 1-3/4	140	50269	1	NUT, HEX 5/16-24
				141	50928	1	SEALANT
				142		81oz	20W-50 OIL
				150	70312	1	SEAL KIT
				151	50416	1	GREASE